

Installation, Operation, Repair And Parts Manual**Description**

SERIES 5300C-X
Cast Iron Small Twin
Piston Pump

Max. Flow Rate:1.5, 2.0, 2.5
and 3.0 gpm
Max. Pressure:500 psi
Max. Speed:1725 rpm
Ports:1/2" NPT inlet
1/2" NPT outlet
Max. Operating Temp.....140° F

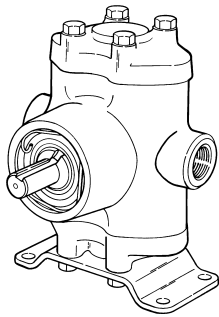
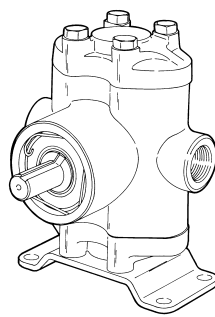

SERIES 5321C & 5322C
Cast Iron Small Twin
Plunger Pump

Max. Flow Rate:2.2 gpm
Max. Pressure:1000 psi
Max. Speed:1725 rpm
Ports:1/2" NPT inlet
1/2" NPT outlet
Max. Operating Temp.....180° F

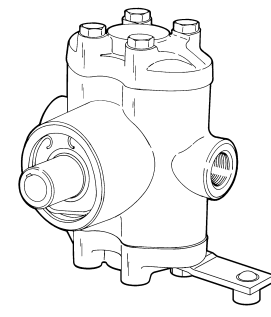

SERIES 5324C
Cast Iron Small Twin
Piston Pump

Max. Flow Rate:2.9 gpm
Max. Pressure:800 psi
Max. Speed:1725 rpm
Ports:1/2" NPT inlet
1/2" NPT outlet
Max. Operating Temp.....140° F

Safety Information

The following special attention notices are used to notify and advise the user of this product of procedures that may be dangerous to the user or result in damage to the product.

NOTE: Notes are used to notify of installation, operation, or maintenance information that is important but not safety related.

CAUTION: Caution is used to indicate the presence of a hazard, which will or can cause minor injury or property damage if the notice is ignored.

WARNING: Warning denotes that a potential hazard exists and indicates procedures that must be followed exactly to either eliminate or reduce the hazard, and to avoid serious personal injury, or prevent future safety problems with the product.

DANGER: Danger is used to indicate the presence of a hazard that will result in severe personal injury, death, or property damage if the notice is ignored.

DANGER: DO NOT pump flammable or explosive fluids such as gasoline, fuel oil, kerosene, etc. DO NOT use in explosive atmospheres. The pump should be used only with liquids compatible with the pump component materials. Failure to follow this warning can result in personal injury and/or property damage and will void the product warranty.

A pressure relief device, such as an unloader, relief valve or balancing regulator must be installed on the outlet side of the pump. Failure to do so could result in personal injury and/or void the warranty.

- Be sure all exposed moving parts such as shafts, couplers and adapters are properly shielded or guarded and that all coupling devices are securely attached before applying power.
- Hollow shaft pumps mounted directly onto power shaft must be prevented from rotating with the power shaft by means of a device such as a torque arm. Pump must float freely on the power shaft and must not be tied rigidly to equipment on which it is mounted.

- Do not exceed recommended speed, pressure and temperature for pump and equipment being used.
- Before servicing, disconnect all power, make sure all pressure in the system is relieved, drain all liquids from the system and flush.
- Secure the discharge lines before starting the pump. An unsecured line may whip, causing personal injury and/or property damage.
- Check hose for weak or worn condition before each use. Make certain that all connections are tight and secure.
- Periodically inspect the pump and the system components. Perform routine maintenance as required (see Maintenance section).
- Protect pump from freezing conditions by draining liquid and pumping rust inhibiting solution, such as antifreeze, through the system, coating the pump interior.
- Use only pipe, hose and fittings rated for the maximum (or greater) PSI rating of the pump.
- Do not use these pumps for pumping water or other liquids for human or animal consumption.

Drive Source Installation

This manual will cover the installation of the basic drive configurations available for the Hypro Small Twin Piston and Plunger pumps. Consult the manufacturer

of your motor or engine for additional information. Read all instructions and general safety information before attempting to install or operate the pump.

Belt/Pulley Drive Installation

Mounting Belts and Pulleys

Mount pulleys as close to pump and motor engine shaft bearings as possible. Check alignment with a straight edge as shown (See Figure 1). Make sure that belt has proper tension. (Too much tension will cause bearing wear; too little will cause slippage.) (See Figure 2). Check with belt and pulley sources for specific recommendation.

To figure proper diameter of pump pulley, multiply motor/engine RPM by diameter of the motor/engine pulley and divide that figure by desired pump speed.

$$\text{Pump Pulley Size} = \frac{\text{Motor RPM} \times \text{Motor Pulley Size}}{\text{Desired Pump Speed}}$$

Refer to pump performance charts to determine desired speed to obtain desired maximum flow.

NOTE: Shaft rotation can be either clockwise or counterclockwise.

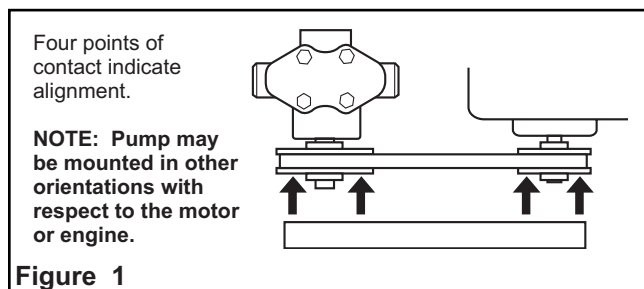

Figure 1

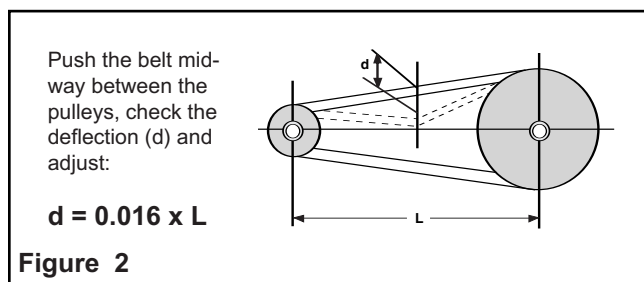

Figure 2

Direct Drive - Flexible Coupling Installation

First, slide coupling ends onto motor/engine and pump shafts as far as possible (See Figure 3). Mount motor/engine and pump onto base, shimming pump or power unit so that shafts are aligned. Leave enough space between ends of shafts to allow coupling disc to be inserted. When alignment is made, slide coupling ends over coupling disc. Leave clearance between coupling ends and center disc. Tighten screws in both coupling ends. For electric motor drive, use couplings rated at least twice the horsepower required to operate pump. For gas engine drive, select couplings rated at three times the required pump horsepower.

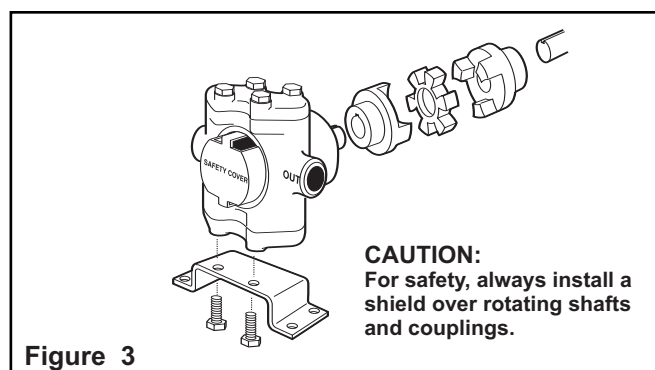

Figure 3

Direct Drive - Hollow Shaft Installation

Hollow shaft models mount directly on the motor or engine shaft (See Figure 4). Adapters are available to convert some solid shaft models for direct shaft mounting. After mounting the pump, always turn it by hand to make sure the pump is operating freely. Never apply power to a pump that appears to be stuck.

CAUTION: Use a torque arm to keep the pump from rotating with the shaft. The pump must be allowed to float on the shaft and must not be tied rigidly to the equipment on which it is mounted.

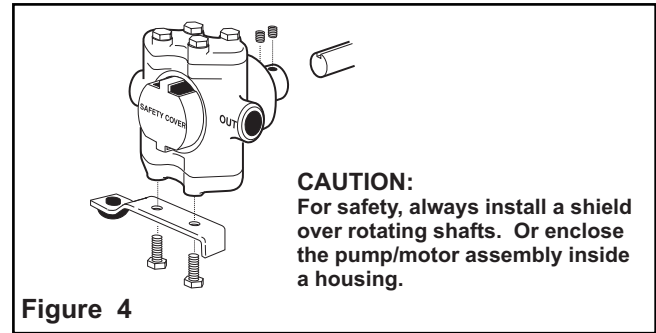

Figure 4

System Installation

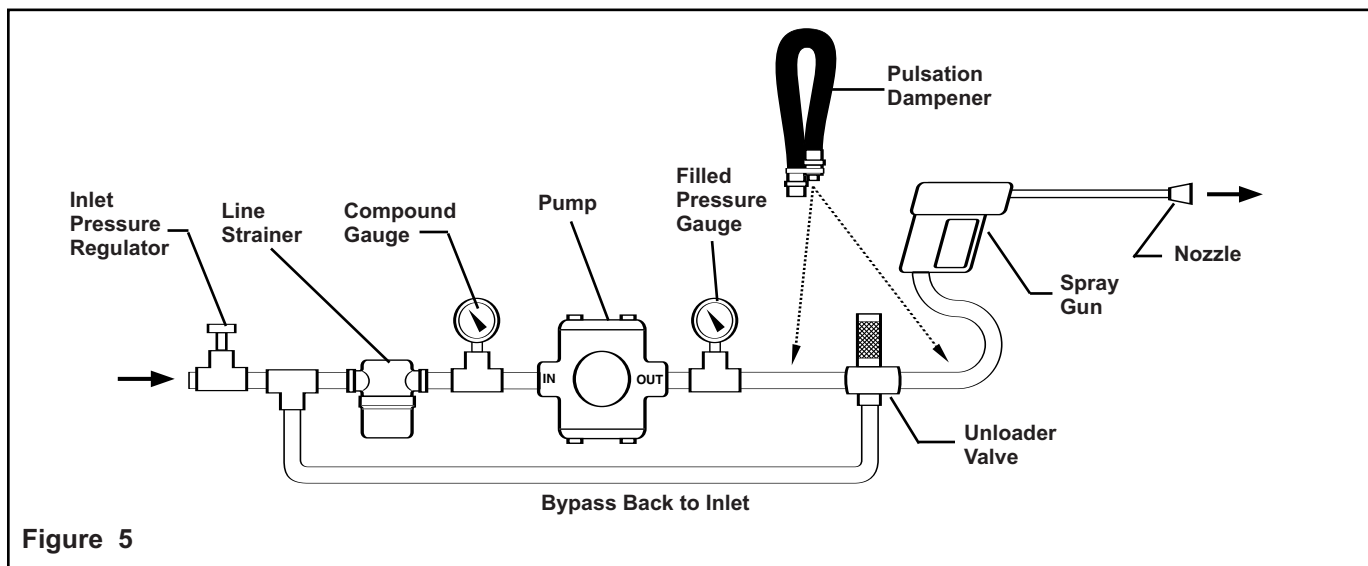

Figure 5

Piston Pump Installation

Accessories should be installed with solid piping and be mounted as close to the pump as possible. The hose must be used right after accessories.

NOTE: If remaining installation is solid piping, a two to four foot length of hose must be installed between accessories and solid piping.

Hose

Selection of the right size and type of hose is vital for good performance. Be sure to hook up to the proper ports on the pump (note markings "IN" and "OUT" on pump castings).

Suction Hose

Always use genuine suction hose compatible with the fluids being pumped and at least the same inside diameter as pump ports. If the suction hose is over 5 feet long, use the next larger size hose. Keep the suction hose as short as possible and restrictions such as elbows, check valves, etc. at a minimum.

Discharge Hose

High pressure pumps require the use of special high pressure discharge hose (2 rayon braid or equivalent). Use a hose rated at least 50% greater than the highest operating

pressure required of pump. **Example:** If required pump pressure is 200 psi, use discharge hose rated at minimum of 300 psi working pressure.

Unloader Valve

The unloader has a very important safety function in your piston pump hookup. The unloader valve protects the pump by unloading pressure when the gun is shut off or discharge is otherwise blocked. This saves the pump and power because the liquid is bypassed at a very low pressure. If the gun is to be shut off for more than 5 minutes, install a pump protector in the inlet side or stop the pump to prevent heat buildup. The length of time may vary due to the original temperature of the fluid being pumped.

Strainers

Use a suction line strainer with at least 3 to 5 times the suction port area in open screen area. For example, an area of approximately 1.1 to 1.9 square inches for a 1/2" suction port. Be sure the screen is suitable for the liquid being pumped. Keep the filter clean. A clogged strainer will cause cavitation, which usually leads to a poor performance and wear of the pump parts.

Compound Gauge (Optional)

The pump should not be subjected to high suction line vacuums. To check on this, install a compound gauge at pump inlet. For ultimate performance and life, the vacuum should be limited to 5 inches of mercury. High vacuum conditions may cause premature product failure and void warranty.

Pulsation Dampener

This device absorbs the shock and smooths out the pump discharge pulsations, providing smoother operation. For the proper operation of many unloader valves, the pulsation dampener should be installed on the discharge side downstream from the unloader valve. However, for maximum system protection, the pulsation dampener may be installed upstream

from the unloader valve, provided the unloader valve will function properly. The dampener can be mounted vertically or horizontally.

Pressure Regulator

Use a pressure regulator to limit incoming pressure to 20 psi when equipped with a suction side injector. Volume, pressure and horsepower figures in pump performance tables do not apply when incoming pressure exceeds 40 psi.

Pressure Gauge/Dampener

Use gauge capable of reading double the pump working pressure. Use a silicone-filled gauge or a gauge dampener to protect the gauge needle against pressure surges and provide easier reading.

Operation

Priming

If the liquid is below level of the pump, some means should be provided in installation to prime pump, such as a foot valve or check valve to hold prime. Keep suction lift to minimum and avoid unnecessary bends in the suction line. Before starting pump, make sure air bleeder valve or spray gun is open, or unloader valve is adjusted to its lowest pressure. After starting pump, open and close gun several times if necessary to aid priming the pump. If pump does not prime within a few seconds, stop motor and inspect installation for suction line leaks or obstructions. Make sure that strainer is not clogged. Be sure that suction line is not obstructed, kinked or blocked.

If the pump is to operate hours at a time, check frequently for:

1. Adequate liquid supply. Pump must not run dry for more than 30 seconds.
2. Temperature rise. Overheating is harmful to bearings and piston cups.

NOTE: Models 53702 and 53703 Inlet Requirements: Pressure feed 20 to 100 psi.

Care of Pump

Your pump will last longer and give best performance when properly taken care of. Proper pump care depends on the liquid being pumped and when pump will be used again. In a normal car wash or detergent cleaning installation (where each application is followed by a clear water rinse), the pump will be kept clean.

After each use, flush pump with a neutralizing solution for the liquid just pumped. Follow with a clear water rinse. This is especially important for corrosive chemicals. Then flush out pump with a 50% solution of automotive ethylene glycol-type radiator antifreeze containing a rust inhibitor, or use a commercial rust inhibitor such as FLUID FILM.

While this flushing is not absolutely necessary for short periods of idleness (as overnight), it is good practice to clean the pump after each use to prevent deposits from forming and damaging the pump. The antifreeze not only coats the interior of the pump with an inhibitor, but acts as a lubricant as well, keeping valves from sticking - and protecting against any remaining moisture freezing in cold weather.

For infrequent use and before long periods of storage, drain pump thoroughly. Open any drain plugs, remove suction hose from liquid, and run pump "dry" from 0 to 30 seconds (**not longer**). Once again, a rust inhibitor should be injected into the pump before both ports are plugged and the pump is stored. Then, plug both ports to keep out air until pump is used again.

Lubrication Schedule

Use a grease gun to lubricate Hypro Series 5300 and 5324 Piston Pumps and Series 5321 and 5322 Plunger Pumps. **DO NOT USE AIR-POWERED GREASE GUNS** as they develop too much pressure and may cause damage to the sealed cam bearing.

Lubrication

EXCEPTION: In applications where FDA approval is required, use one of these greases: Chevron FM#2, Mobile FM#2 Keystone (Penwalt Corp.) Nevastane SP Medium. **Lubricate every 50 hours or monthly.**

With a screwdriver or flat tool, apply a generous dab of grease to outer diameter surface of cam bearing at top and bottom where bearing contacts connecting rod.

Do not grease excessively.

Check periodically and scrape out (do not WASH out) any excess grease from pump cavity.

Repair Instructions

Recommended Repair Tools For Hypro Small Twin Piston/Plunger Pumps

Ref. Part No.	Description	Used for Series		
		5321	5324	5300
A	Seal Ring Seating Tool			•
B	Valve Cage Extractor	•	•	•
C	Main Bearing Support Tool	•	•	•
D	Cam Bearing Support Tool	•	•	•
E	Support Bars (Qty 2)	•	•	•
F	Pry Bar	•	•	•
G	Wire Brush	•	•	•
H	Wire Brush Holder	•	•	•
I	Valve Seat Extractor	•	•	•
J	Seal Ring Seating Tool	•	•	•
K	3/16" Allen Wrench	•	•	•
L	1/8" Allen Wrench	•	•	•
M	3/20-0009 1/16" Allen Wrench	•	•	•

Recommended Shop Tools

Bench Press, Arbor Press, Air Gun or Electric Hand Drill, Metal Pipe, Support Fixture, (3" diameter x 4 1/2" high), Ratchet Handle Wrench with 9/16" Hex Socket, Bolt (3/8" diameter x 4 1/2" long), No. 320 Grit Emory Cloth, Pliers, Small Knife, Large File, Claw Hammer, Standard Screwdriver, Lubricating Spray (WD-40 or LPS), Wire Brush (hand or machine), Stationary Belt Sander, and Cleaning Solvent Tank (recommended)

Inspection of Pump Parts

When disassembling pump, thoroughly inspect all parts and replace if necessary, with special consideration given to the following areas:

1. Inspect Pump Body for erosion at O-ring seal points in Valve and Piston bores. Check for wear resulting from Main Bearings turning in Housing, especially the Front Bearing area closest to the Cam Bearing. Check for cracks in the Pump Body, particularly at the discharge port and along the casting seam (See Figure 7).
2. Inspect for excessive wear on the Cylinder Heads. This can result from erosion and/or valve seat hammer (See Figure 7).
3. Inspect for pitting and general wear in the United Valves, particularly where the Poppets seal against the seat. If this area is worn, replace all four Valves (See Figure 7).
4. Inspect the Connecting Rod. If there is more than .007" wear in the total space between the Connecting Rod and Cam Bearing, the Connecting Rod should be replaced. This can be determined using a feeler gauge. The Cam Bearing should also be inspected as a bad cam bearing is the most common cause of a damaged Connecting Rod. A worn Connecting Rod results in low volume, low pressure, a hammering sound and the pump running hot (See Figure 8).

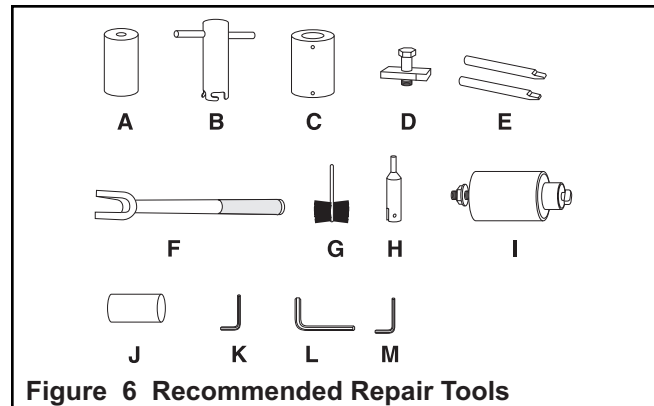

Figure 6 Recommended Repair Tools

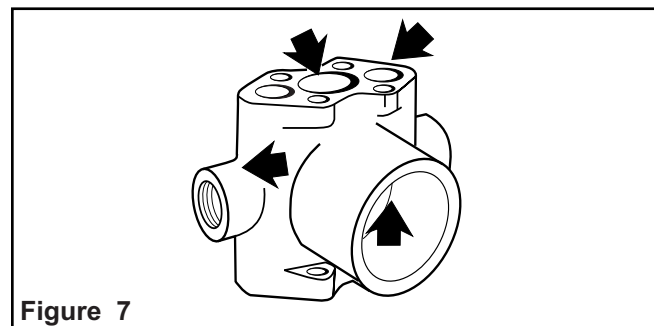

Figure 7

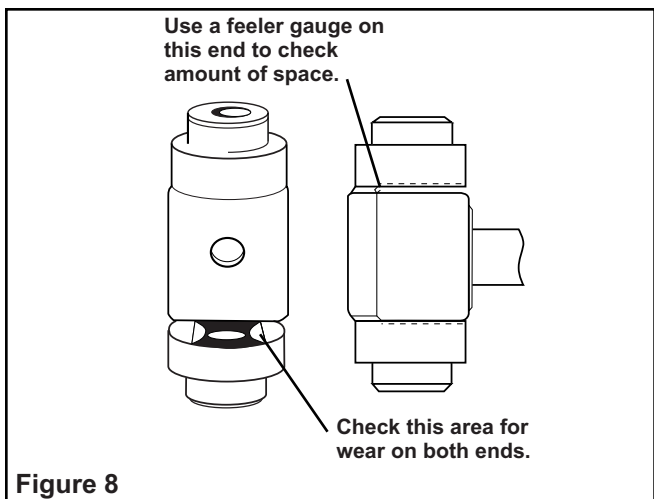

Figure 8

5. Inspect Crankshaft Assembly for general wear. Rotate Cam Bearing and Main Bearings to check for roughness due to moisture contamination or lack of grease. If main bearings do not turn smoothly or appear to be damaged, they should be replaced. If cam bearing is damaged, a new Crankshaft Sub-assembly should be installed and the connecting rod inspected for wear (See Figure 8).

NOTE: Always use new O-rings, Cups, Seal Rings, Support Rings, Guides, Washers, and Piston Cap Screws. If new Valves are needed, always replace the complete set of four.

Series 5300X, 5321, 5322, & 5324 Disassembly, Repair, & Reassembly Instructions

NOTE: Due to variations in each model's Piston or Plunger Stack, differences in the instructions for each model will be denoted with italics and brackets.

HAZARDOUS SUBSTANCE ALERT: Always drain and flush pump before servicing or disassembly.

Valve Assembly Removal:

1. Place the Pump upright in a bench-mounted vise with the Safety Cover facing out; then, using a 9/16" wrench, remove the Cylinder Head Bolts.
2. Remove the Cylinder Head.
3. Using a screwdriver or knife, remove the Cylinder Head O-ring from the Cylinder Head.
4. Using the Seat and Cage End Valve Extraction Tools, remove the Unitized Valve Assembly from the Pump Body (See Figures 9 and 10).

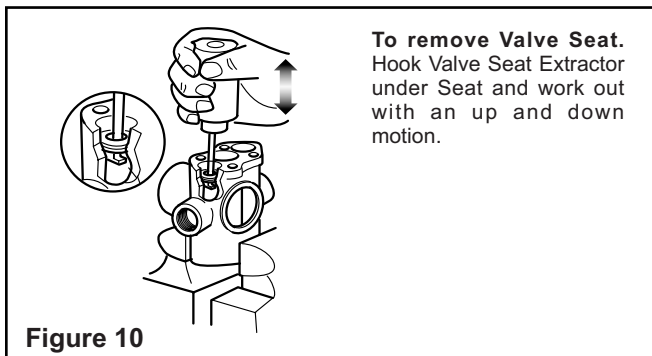
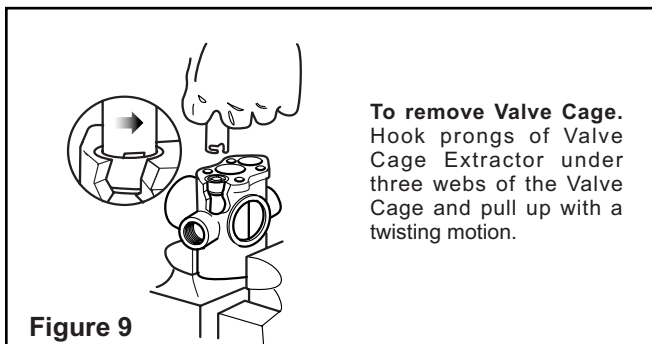

5. Rotate the Pump Shaft so the Cam Bearing is in the upstroke position; then using a 3/16" Allen wrench, remove the Cap Screw from the Piston Assembly for Models 5300X and 5324 [For Models 5321 & 5322, remove the Plunger from the Pump Body after the Cap Screw is removed].

6. Turn the Pump over and repeat Steps 1 through 5.
7. Position the Pump horizontally in the vise with the Safety Cover side up.
8. Use a claw hammer to remove the Grease fitting (See Figure 11). In most cases, the Grease Fitting is damaged during removal and must be replaced [At this time, remove the Connecting Rod in Models 5321 & 5322].

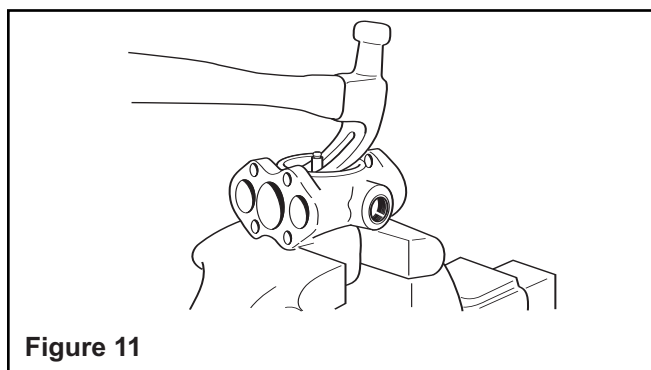

Piston Sleeve Assembly Removal and Cleanup (5300X and 5324 only)

See Figures 12 & 13 for Piston Stack Components

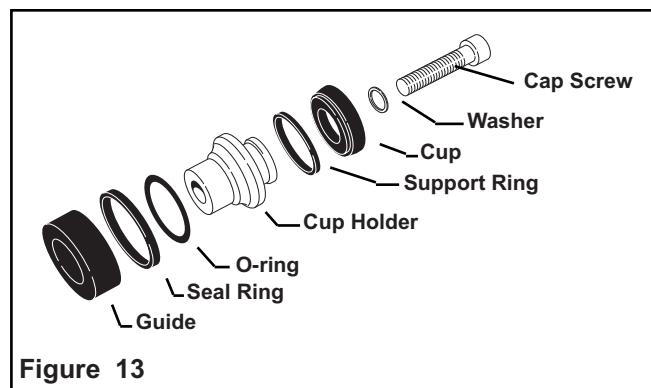
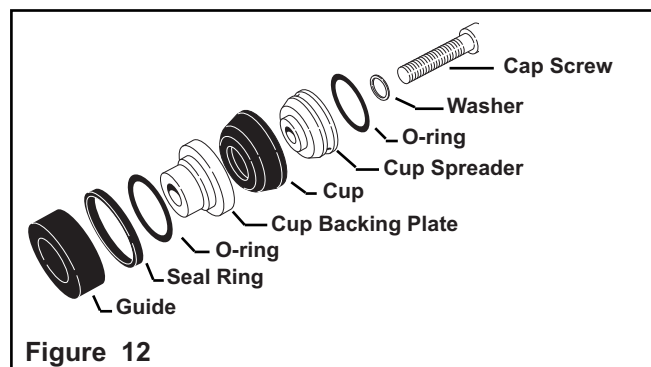

1. Leave the pump body horizontal in the bench vise to remove the Cylinder Sleeves and Piston Assemblies. Make sure the Cam Bearing is in the upstroke position. Place one of the metal bars provided in the tool kit on the Cylinder Sleeve.
2. Using a hammer, gently tap the Cylinder Sleeve out of the Cylinder Head end of the pump body. The Piston will also come out with the Cylinder sleeve.
3. Turn the pump around in the vise and repeat Steps 1 and 2.
4. Remove the Connecting Rod.
5. Remove the Piston Assembly from the Cylinder Sleeve by pushing it out with your fingers; then remove the washer.
6. Clean the cylinder sleeves using the burnishing adapter supplied with the tool kit. The adapter is mounted to an electric motor shaft. Insert the Cylinder Sleeve (brass retainer end facing out) into the furnishing adapter and polish the inside surface using a No. 320 grit emery cloth. Use a wire brush to clean the outside of the cylinder sleeve. Upon inspection, if pitting or scratches still show on the inside of the cylinder sleeve, the cylinder sleeve must be replaced along with the cylinder sleeve o-ring.

Crankshaft Assembly Removal (All Models)

WARNING: Special attention should be exercised when working with retaining rings. Always wear safety goggles when working with spring or tension-loaded fasteners or devices.

1. Place the pump on a flat surface with the shaft side facing up; then remove the retaining ring from the bearing bore.
2. Using a metal pipe 3" in diameter by 4-1/2" high as a support fixture, place the pump on the fixture, shaft side down. Position the fixture with pump on the arbor press (See Figure 14).

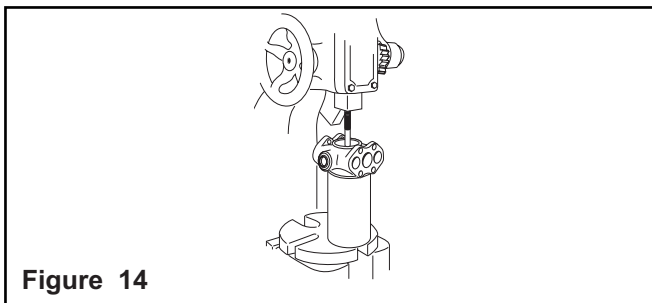

Figure 14

3. Place a bolt 3/8" in diameter by 4-1/2" long threaded end up on the Crankshaft Cam Bearing; then, using the arbor press ram on the bolt, push the Crankshaft Assembly out of the Pump Body (See Figure 14).

Plunger Cartridge Removal/Disassembly/Reassembly (Series 5321 and 5322 only)

See Figure 15 for Plunger Cartridge Components

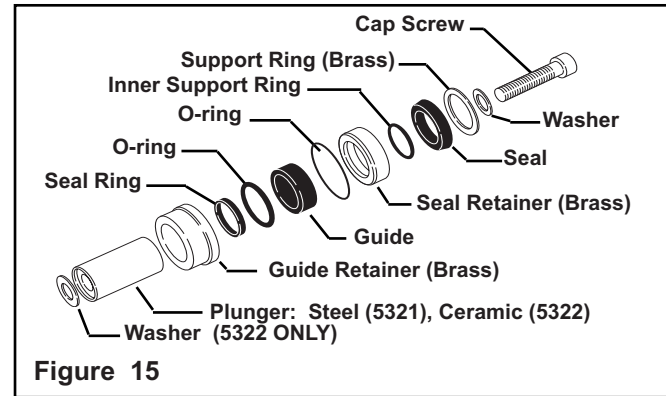

Figure 15

To Remove the Plunger Cartridges from the Pump Body:

1. Position the pump upright on the arbor press with the Safety Cover opening facing out.
2. Place the Plunger Cartridge Extractor Tool, machined side down, on the Guide Retainer inside the pump body.
3. Place the bolt threaded-end down through the Plunger Bore on the other end of the pump until it rests in the counter-sink hole on the Cartridge Extractor Tool.
4. Place the arbor press ram on the bolt head and push both the Seal and Guide Retainer out of the pump body (See Figure 16).
5. Turn the pump over and repeat Steps 1 through 4.

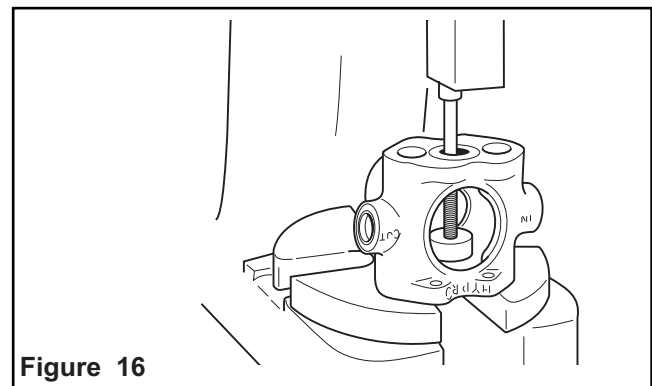

Figure 16

To Disassemble the Guide and Seal Cartridges:

1. Remove the Guide from the Guide Retainer by pulling it out with one finger.

NOTE: If the guide does not come out in this manner, use a screwdriver and a hammer to gently break off a section of the Guide, being careful not to damage the Guide Retainer. The remaining portion of the Guide will then fall out.

2. With a small knife blade, remove the O-ring/Seal Ring combination from the Guide Retainer.
3. Using a small knife blade, remove the Brass Support Ring and Support Ring/Seal combination from the Seal Retainer.
4. Inspect and clean the Brass Guide and Seal Retainers. Clean them with a wire brush and check them for burrs and nicks. Use 320 grit emery cloth to remove burrs.

To Reassemble the Plunger Cartridges:

1. Lightly lubricate the O-ring and place it around the Seal Ring.
2. Position the O-ring/Seal Ring combination in the Guide Retainer at a 45 degree angle.
3. Using the Guide, seat the O-ring/Seal Ring Combination into the Guide Retainer, leaving the Guide in the Guide Retainer.
4. Place the Guide Retainer on a flat surface so that the exposed portion of the Guide is down.
5. Place the cap screw end of the Plunger into the Guide Retainer and press it through until the Plunger is flush with the bottom of the Guide Retainer.
6. Turn the Cartridge over and push the Guide Retainer down the Plunger until it is flush with the bottom of the Plunger.

Seal Retainer Cartridge:

1. Place the beveled side of the Inner Support Ring in the grooved side of the Seal; then, place the Seal Retainer over the Support Ring side of the Support Ring/Seal combination.
2. Press the above items in with your fingers until the Support Ring/Seal combination bottoms out inside the Seal Retainer.
3. Place the Brass Support Ring on the open side of the Seal Retainer.

Clean-up of the Pump Body and Heads (All Models)

1. Using the port wire brush with an air gun or electric hand drill, clean the outlet port and inlet port, plus the valve and piston bores in the Pump Body.
2. Use a hand file or belt sander to clean corrosion and rust from the top and bottom of the Pump Body and the bottoms of the cylinder Heads.
3. After performing Steps 1 and 2, Hypro recommends that the pump Body and Cylinder Head be further cleaned in a solvent tank to remove any remaining rust and corrosion particles.

NOTE: If the solvent cleaning is not performed, the valve and piston bores must be wiped as clean as possible.

Crankshaft and Main Bearing Disassembly/Reassembly (All Models)

Disassembly:

1. To remove the Front Main Bearing from the Crankshaft, position a pipe support fixture on the arbor press; then, place two metal bars parallel to each other, one on each side of the fixture (See Figure 17).
2. Place the Crankshaft Assembly in the fixture, drive end up, with the metal bars between the Bearing and fixture to support the Outer Bearing (See Figure 17).

NOTE: Make sure the metal bars do not touch the Retaining Ring on the Crankshaft.

3. Using the arbor press, press the Crankshaft through the Bearing (See Figure 17).

WARNING: Special attention should be exercised when working with retaining rings. Always wear safety goggles when working with spring or tension-loaded fasteners or devices.

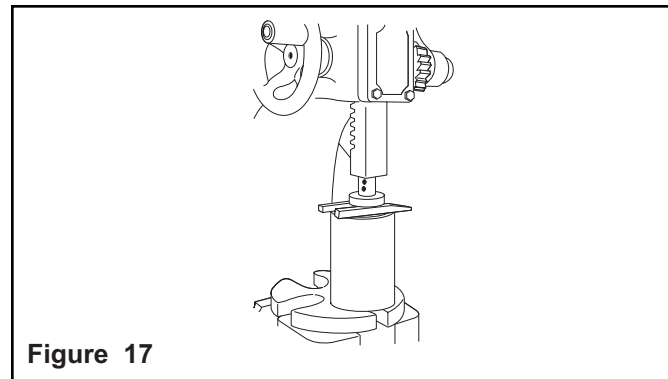

Figure 17

4. Remove the first Retaining Ring on the Crankshaft with a pliers and the second Retaining Ring with a screwdriver.
5. Press out the back Main Bearing in the same manner as the front Main Bearing (Refer to Steps 1 through 3).
6. Remove the Slinger Ring by working it off the Shaft.

Reassembly

1. Install the back Main Bearing first. Place the Bearing on the small opening end of the Main Bearing Support Tool with the Slinger Ring on top of the Bearing, and position it on the arbor press.

WARNING: Special attention should be exercised when working with retaining rings. Always wear safety goggles when working with spring or tension-loaded fasteners or devices.

2. Place the Crankshaft in the Bearing and use the arbor press ram to press the Crankshaft through the Bearing until the Retaining Ring can be installed in the second groove of the Crankshaft (See Figure 18).

NOTE: Make sure the Slinger Ring does not touch the Cam Bearing on the Crankshaft when installing Retaining Rings.

3. Install both Retaining Rings on the Crankshaft.

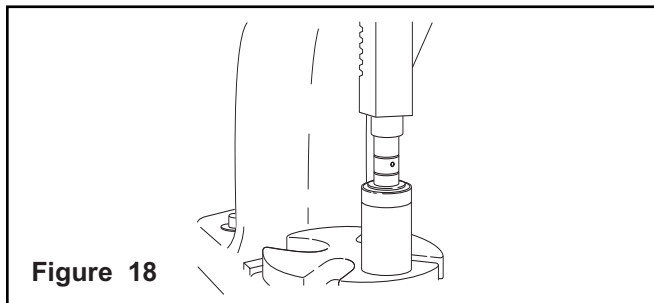

Figure 18

4. Place the Pump Body, Safety Cover side down, on the arbor press.
5. Place the Crankshaft, Back Bearing down, into the bearing bore of the Pump Body.
6. Place the Main Bearing Support Tool, large opening down, over the Crankshaft.
7. Use the arbor press ram to press the Crankshaft Assembly into the bearing bore of the pump body until it bottoms out.
8. Place the front Main Bearing on the Crankshaft until it touches the pump body.
9. Place the smaller opening end of the Main Bearing Support Tool over the Crankshaft (See Figure 19).

10. Turn the Pump and Main Bearing Support Tool over so that the Safety Cover side of the pump is facing up.
11. Position the Cam Bearing Support Tool with the bolt head down over the Safety Cover opening on the pump body.

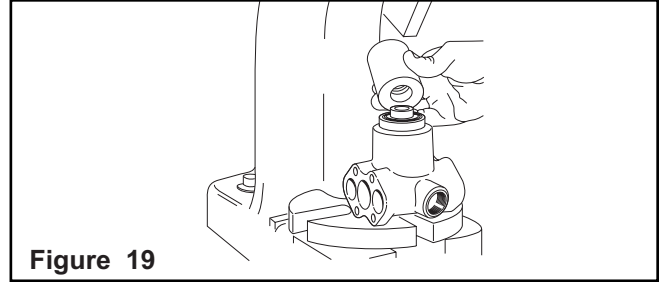

Figure 19

12. Turn the bolt down by hand until it comes in contact with the Cam Bearing.
13. Use the arbor press ram to press down on the bolt in the Cam Bearing Support Tool to push the front Main Bearing into the pump bearing bore until it comes in contact with the first retaining ring on the crankshaft.
14. Turn the pump over to install the Retaining Ring in the pump bearing bore.

Valve Assembly Installation

1. Lubricate the Pump Body Valve Bores.
2. Install the Valve Assemblies into the **INLET** side valve bores with the plastic valve cage portion facing **UP** (See Figure 20).
3. Install the Valve Assemblies into the **OUTLET** side valve bores with the metal valve seat portion facing **UP** (See Figure 21).
4. Apply a small amount of grease to the top and bottom inside surfaces of the Connecting Rod. (The area where the Cam Bearing comes in contact with the Connecting Rod.)

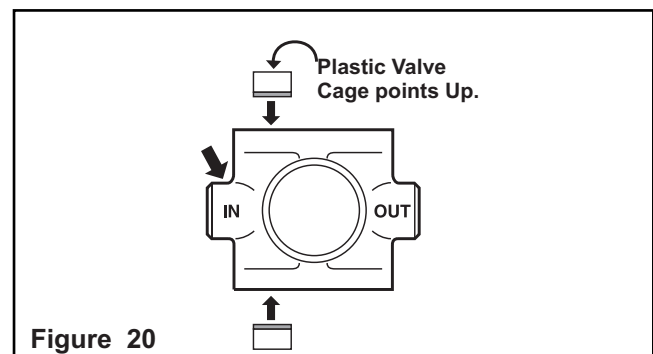
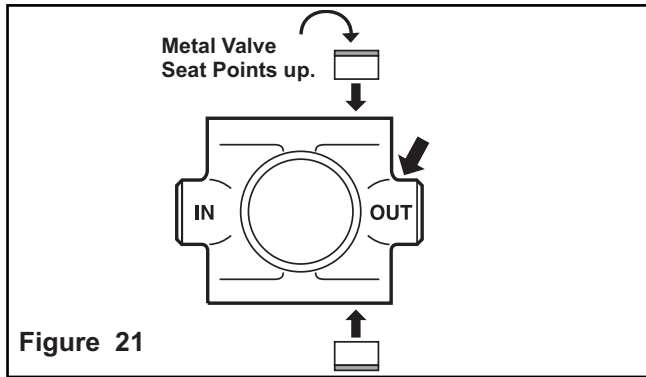

Figure 20

- Place the Connecting Rod on the Cam Bearing.



Cylinder Sleeve and Piston Stack Installation (Series 5300X and 5324 only)

NOTE: Clean the cylinder sleeves using the Burnishing Adapter provided with the tool kit. The Burnishing Adapter is to be mounted on an electric motor shaft.

- Insert the Cylinder Sleeve (Brass Retainer End out) into the Burnishing Adapter and polish the inside surface using a No. 320 grit emery cloth.
- Use a wire brush to clean the outside of the Cylinder Sleeve.

NOTE: Upon inspection, if pitting or scratches still show on the inside of the Cylinder Sleeve, the Cylinder Sleeve and the Cylinder Sleeve O-ring should be replaced.

- Insert the Cylinder Sleeve into the cylinder bore of the Pump Body.
- Lubricate and place a new Cylinder Sleeve O-ring on top of the Cylinder Sleeve.
- Place a Brass Retainer on top of the O-ring.
- Insert the Guide into the Cylinder Sleeve, making sure the Guide is properly seated on the Connecting Rod inside the Pump Body.
- Place the Seal Ring at a 45 degree angle on top of the Guide; then, using the Seal Ring Seating Tool, press the Seal Ring into the Cylinder sleeve.
- Lubricate the O-ring and place it on the Cup Backing Plate.
- Install the Cup Backing Plate on top of the Seal Ring in the piston bore, O-ring end down.
- Lubricate the Cup and set it on top of the Cup Backing Plate inside the piston bore.
- Lubricate the O-ring and install it on the Cup Spreader.

- Place the Cup Spreader end opposite O-ring in the Cup inside the piston bore.
- Place the Washer on the Piston Cap Screw, insert it through the Piston Assembly, then tighten it to 130 in. lbs. of torque.

- Turn the Pump over and repeat Steps 2 through 13.

Plunger Assembly Installation (Series 5321 and 5322 only)

NOTE: Make sure the Cam Bearing is in the upstroke position when installing the Cylinder Sleeves and Piston Assemblies.

- Place the assembled Guide Retainer Cartridge and Plunger into the plunger bore of the Pump body, making sure the Plunger and Connecting Rod seat together properly inside the Pump Body.
- Lubricate the O-ring and place it on top of the Guide Retainer Cartridge.
- Place the Seal Retainer Cartridge over the Plunger (beveled side down), and press it by hand into the Pump Plunger bore.
- Place a Washer on the Plunger Cap Screw, insert it through the Plunger and tighten it to 100 to 115 In. Lbs. of torque.
- Turn the Pump over and repeat Steps 1 through 4.

Head and Grease Fitting Installation (All Models)

- Install the O-ring into the Pump Cylinder head.
- Place the Pump Body upright in a vise; then, place the Head on the Pump Body.
- Secure the head to the Pump Body with the Head Bolts; then, alternately and evenly (in a criss-cross pattern) tighten the head Bolts.
- Turn the Pump over and repeat Steps 1 through 3.
- To install the Grease Fitting into the Cam Bearing, place the pump on the arbor press with the Safety Cover side facing up; then press the Grease Fitting in with the arbor press ram.
- Grease the pump according to the Lubrication Instructions.
- Install the safety cover.

Troubleshooting

Symptom	Probable Cause(s)	Corrective Action(s)
No Flow or Low Flow	Pump not primed	Refer to Priming in the Operation Section.
	Air leaks in suction line	Check and reseal inlet fittings.
	Blocked or clogged line strainer	Inspect strainer and clear any debris from screen.
	Undersize suction line or collapsed hose	Suction line should be the same diameter as inlet port of Pump or larger.
	Nozzle clogged	Clear nozzle or replace.
	Unloader or Relief Valve not functioning properly	Repair or replace Relief Valve.
Low pressure	Debris in Valves	Remove debris. See Repair section.
	Valves worn	Replace Valves. See Repair section.
	Unloader or Relief Valve not functioning properly	Repair or replace relief valve.
	Pump not primed	See priming in Operation section.
Pump Leaking	Seals worn	Replace Seals. See Repair section.
	Body cracked	Replace Body. See Repair section.

Performance Data

Series 53702

Pressure	100 psi	300 psi	500 psi	700 psi	1000 psi					
RPM	GPM	HP	GPM	HP	GPM	HP				
3450	2.2	.4	2.2	.7	2.1	.9	2.1	1.2	2.0	1.5

Pressure	(689.4 KPa)	2000 KPa	4000 KPa	5000 KPa	(6894 KPa)					
RPM	l/m	w	l/m	w	l/m	w				
3450	8.5	298	8.3	491	7.9	756	7.7	888	7.4	1118

Series 53703

Pressure	100 psi	300 psi	500 psi	700 psi	1000 psi					
RPM	GPM	HP	GPM	HP	GPM	HP				
3100	2.3	.4	2.2	.7	2.1	.9	2.1	1.2	2.0	1.5

Pressure	(689.4 KPa)	2000 KPa	4000 KPa	5000 KPa	(6894 KPa)					
RPM	l/m	w	l/m	w	l/m	w				
3100	8.5	298	8.3	491	8.0	756	7.9	888	7.7	1118

Series 5300C-X

Model	50 psi		100 psi		200 psi		300 psi		400 psi		500 psi		
	RPM	GPM	HP	GPM	HP	GPM	HP	GPM	HP	GPM	HP	GPM	HP
5315C	1725	1.56	.12	1.52	.15	1.50	.28	1.47	.35	1.45	.43	1.44	.56
5320C	1725	2.22	.21	2.18	.28	2.16	.43	2.12	.57	2.11	.71	2.10	.83
5325C	1725	2.56	.25	2.54	.37	2.52	.52	2.50	.68	2.48	.82	2.44	.96
5330C	1725	3.02	.37	3.01	.49	3.00	.74	2.98	.92	2.96	1.11	2.94	1.23

	7 BAR		14 BAR		21 BAR		27.5 BAR		34.5 BAR	
	RPM	L/min.	W	L/min.	W	L/min.	W	L/min.	W	L/min.
1725	5.8	100	5.7	200	5.6	300	5.5	300	5.5	400
1725	8.3	200	8.2	300	8.0	400	8.0	500	8.0	600
1725	9.6	300	9.5	400	9.5	500	9.4	600	9.2	700
1725	11.4	400	11.4	600	11.3	700	11.2	800	11.1	900

NOTE: Above performance figures based on constant speed dynamometer tests, pumping water at one foot (approx.) suction lift with no pulsation damper. Performance will vary with application.

Series 5321C and 5322C

	100 psi		300 psi		500 psi		700 psi		1000 psi	
RPM	GPM	HP	GPM	HP	GPM	HP	GPM	HP	GPM	HP
900	1.1	.2	1.1	.4	1.1	.5	1.1	.6	1.1	.8
1200	1.5	.3	1.5	.5	1.5	.6	1.5	.8	1.4	1.0
1450	1.8	.4	1.8	.6	1.8	.7	1.8	.9	1.8	1.2
1725	2.2	.4	2.1	.7	2.1	.8	2.1	1.1	2.1	1.4

	7 BAR		20 BAR		40 BAR		50 BAR		69 BAR	
RPM	L/min.	W	L/min.	W	L/min.	W	L/min.	W	L/min.	W
900	4.2	165	4.2	261	4.2	399	4.2	461	4.1	575
1200	5.8	224	5.6	357	5.5	536	5.5	603	5.4	739
1450	6.9	269	6.8	399	6.7	601	6.7	700	6.6	888
1725	8.2	321	8.1	459	8.0	692	8.0	815	7.9	1059

Series 5324C

	100 psi		200 psi		300 psi		400 psi		500 psi		600 psi		700 psi		800 psi	
RPM	GPM	HP	GPM	HP	GPM	HP	GPM	HP	GPM	HP	GPM	HP	GPM	HP	GPM	HP
600	.96	.12	.94	.19	.94	.26	.95	.33	.94	.39	.93	.45	.93	.52	.93	.58
900	1.51	.19	1.49	.30	1.48	.41	1.47	.50	1.47	.60	1.46	.69	1.46	.78	1.45	.87
1200	2.00	.28	1.98	.41	1.97	.55	1.96	.67	1.96	.81	1.95	.93	1.94	1.06	1.93	1.16
1450	2.42	.34	2.40	.50	2.38	.67	2.37	.83	2.36	.97	2.35	1.13	2.33	1.27	2.32	1.42
1725	2.90	.40	2.89	.59	2.87	.80	2.85	1.00	2.83	1.19	2.81	1.38	2.80	1.54	2.79	1.69

	7 BAR		21 BAR		34.5 BAR		48 BAR		55 BAR	
RPM	L/min.	W	L/min.	W	L/min.	W	L/min.	W	L/min.	W
900	5.7	200	5.7	300	5.7	500	5.7	600	5.7	700
1200	7.6	200	7.6	500	7.6	600	7.2	800	7.2	900
1450	9.1	300	9.1	500	9.1	800	8.7	1000	8.7	1100
1725	11.0	300	11.0	600	10.6	900	10.6	1200	10.6	1300

Models 5315C-X, 5320C-X, 5325C-X and 5330C-X

NOTE: When ordering parts, give QUANTITY, PART NUMBER, DESCRIPTION, and COMPLETE MODEL NUMBER. Reference numbers are used ONLY to identify parts in the drawing and are NOT to be used as order numbers.

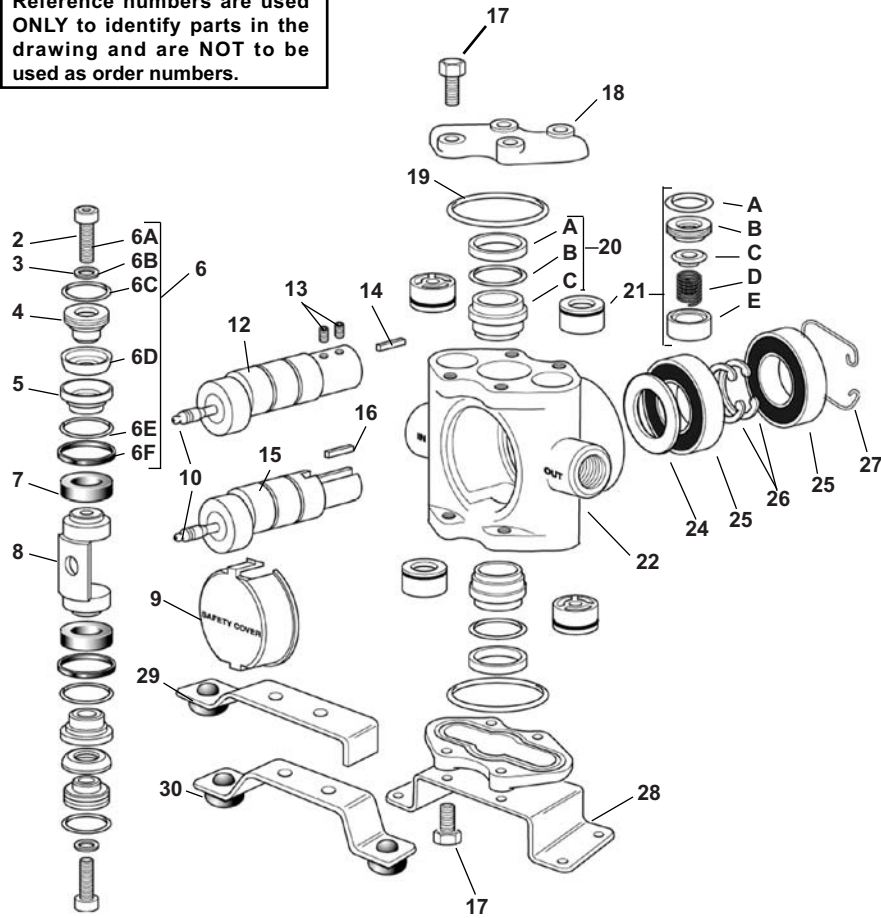

Piston Stack Parts Kit

Leather Cup Kit No. 3430-0007

Consists of two each of the following parts: No. 2220-0012 Piston Cap Screw (Ref. 6A), No. 2270-0011 Washer (Ref. 6B), No. 1720-0029 O-ring (Ref. 6C), No. 2150-0002 Leather Cup (Ref. 6D), No. 1720-0039 O-Ring (Ref. 6E), and No. 1440-0008 Seal Ring (Ref. 6F).

Rubber Cup Kit No. 3430-0009

Same as above kit except with No. 2150-0005 Rubber Cups.

Piston Stack and Guide Parts Kits

Leather Cup and Guide Kit No. 3430-0008

Consists of Leather Cup Kit No. 3430-0007 plus two No. 1440-0004 Piston Guides (Ref. 7).

Rubber Cup and Guide Kit No. 3430-0010

Consists of Rubber Cup Kit No. 3430-0009 plus two No. 1440-0004 Piston Guides.

Teflon Cup and Guide Kit No. 3430-0046

Consists of Teflon Cup Stack Kit plus 2 Piston Guides.

Crankshaft Assemblies

Sub-Assemblies include Shaft (Ref. 12 or 15) with Cam Bearing, Grease Fitting Assembly (Ref. 10), Set Screws for Hollow Shaft (Ref. 13) and Spline Key (Ref. 14 or 16).

Complete Assemblies include the Sub-Assembly plus parts identified by Reference Numbers 24-26.

Sub-Assembly Part No.	Complete Assembly Part No.	Pump Model
with 5/8" (I.D.) Hollow Shaft (Ref. 12)		
5501-5315	5500-5315	5315C-H
5501-5320	5500-5320	5320C-H
5501-5325	5500-5325	5325C-H
5501-5330	5500-5330	5330C-H
with 5/8" Solid Shaft (Ref. 15)		
5001-5315	5000-5315	5315C
5001-5320	5000-5320	5320C
5001-5325	5000-5325	5325C
5001-5330	5000-5330	5330C

Ref. No.	Qty. Req'd.	Part No.	Description
2	2	2220-0012	Piston Cap Screw
3	2	2270-0011	Washer
4	2	1830-0017	Piston Cup Spreader
5	2	1410-0030	Cup Backing Plate
6	1		Piston Stack Parts Kit (see listing above)
7	2	1440-0004	Piston Guide
8	1	0502-5300	Connecting Rod
9	1	0608-5300	Safety Cover
10	1	2405-0006	Grease Fitting Assembly
12	1		Crankshaft Assemblies — Hollow Shaft Models, see listing above
13	2	2230-0017	Set Screw for Hollow Shaft
14	1	1610-0011	Spline Key for Hollow Shaft
15	1		Crankshaft Assemblies — Solid Shaft Models, see listing above
16	1	1610-0007	Spline Key for Solid Shaft
17	8	2210-0062	Cylinder Head Bolt
18	2	0204-5300C	Cylinder Head (Cast Iron)
19	2	1720-0038	O-ring for Cylinder Head
20	1	3430-0209	Ni-Resist Cylinder Sleeve Assembly Consists of two each of No. 1830-0033 Retainer (Ref. A), No. 1720-0079 O-ring (Ref. V), and No. 3550-0018 Sleeve (Ref. C)

Ref. No.	Qty. Req'd.	Part No.	Description
21	1 set	3430-0197	Set of four No. 3400-0073 Unitized Valve Assemblies: Consists of four each: O-ring (Ref. A), Valve Seat (Ref. B), Valve Poppet (Ref. C), Valve Spring (Ref. D), Valve Spring Retainer (Ref. E)
22	1	0108-5300C	Body (Cast Iron)
24	1	2130-0007	Bearing Shield
25	2	2008-0001	Main Bearing (Ball Bearing)
26	2	1810-0013	Bearing Retainer Ring (shaft)
27	1	1820-0025	Bearing Retainer Ring (housing)
28	1	1510-0056	Mounting Base
29	1	2820-0040	Torque Arm - for Electric Motor Mounting
30	1	2820-0042	Torque Arm - for Gas Engine Mounting

Models 5321C and 5322C

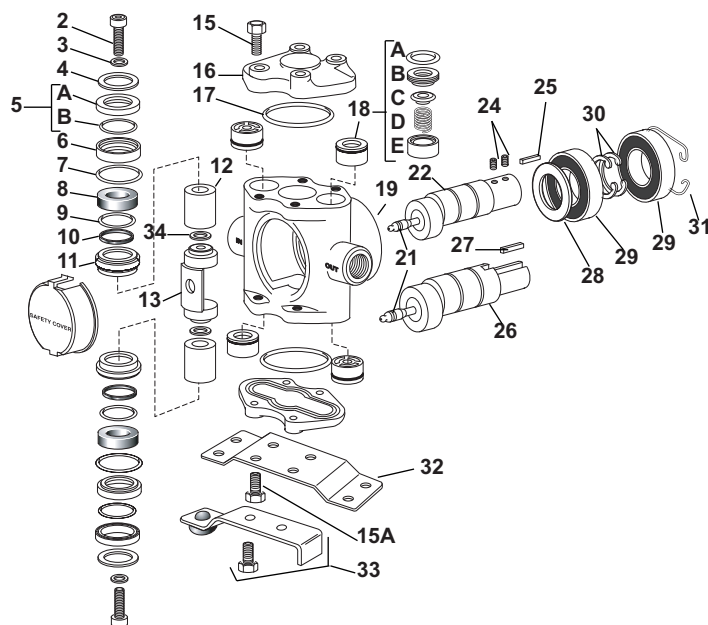

Plunger Parts Kits

Plunger Stack Parts Kit No. 3430-0144 (Model 5321)

Consists of two each of the following parts: No. 1440-0010 Seal Rings, No. 1440-0037 Guides, No. 1720-0064 O-rings, No. 1720-0079 O-rings, No. 2150-0027 Seal Assemblies, No. 2220-0039 Socket Head Cap Screws, and No. 2270-0042 Washers.

Plunger Parts Kit No. 3430-0145 (Model 5321)

Consists of one No. 3430-0144 Plunger Stack Parts Kit and two No. 3500-0021 Plungers.

Plunger Stack Parts Kit No. 3430-0291 (Model 5322)

Consists of two each of the following parts: No. 1440-0010 Seal Rings, No. 1440-0037 Guides, No. 1720-0064 O-rings, No. 1720-0079 O-rings, No. 2150-0027 Seal Assemblies, No. 2220-0039 Socket Head Cap Screws, and No. 2270-0042 Washers.

Plunger Parts Kit No. 3430-0292 (Model 5322)

Consists of one No. 3430-0291 Plunger Stack Parts Kit and two No. 3500-0036 Plungers.

Crankshaft Assemblies

Solid Shaft Sub-Assembly No. 5001-5321

Consists of one each of the following parts: No. 0500-5321 Crankshaft, No. 1600-0014 Crankpin Retainer, No. 2007-0029 Cam Bearing, No. 2405-0006 Grease Fitting Assembly, and No. 1610-0007 Key.

Hollow Shaft Sub-Assembly No. 5501-5321

Consists of one No. 0550-5321 Crankshaft, one No. 2007-0029 Cam Bearing, one No. 2405-0006 Grease Fitting Assembly, one No. 1610-0011 Key, and two No. 2230-0017 Set Screws.

Hollow Shaft Assembly No. 5500-5321

Consists of one No. 5501-5321 Crankshaft Sub-Assembly, two No. 1810-0013 Retaining Rings, two No. 2008-0001 Main Bearings, and one No. 2130-0007 Bearing Shield.

Ref. No.	Qty. Req'd.	Part No.	Description
2	2	2220-0039	Socket Head Cap Screw
3	2	2270-0042	Washer
4	2	1830-0056	Retainer
5	2	2150-0027	Seal Assembly: Consists of No. 2150-0049 Seal (Ref. A) and No. 1440-0061 Support Ring (Ref. B)
6	2	1830-0054	Seal Retainer
7	2	1720-0079	O-ring for Seal Retainer
8	2	1440-0037	Guide
9	2	1720-0064	O-ring for Seal Ring
10	2	1440-0010	Seal Ring
11	2	1830-0053	Guide Retainer
12	2	3500-0021	Plunger (steel, Model 5321)
12	2	3500-0036	Plunger (ceramic, Model 5322)
13	1	0502-5300	Connecting Rod (Model 5321)
13	1	0504-5300	Connecting Rod (Model 5322)
14	1	0608-5300	Safety Cover
15	*	2210-0063	Cylinder Head Bolt (8 bolts required for Model 5321C-H Hollow Shaft Pump; 4 bolts required for Top Cylinder Head ONLY on Solid Shaft Pumps)
15A	4	2210-0064	Extra Long Cylinder Head Bolt for securing mounting base to Solid Shaft Models
16	2	0201-5300C	Cylinder Head (Cast Iron)
17	2	1720-0038	O-ring for Cylinder Head
18	1 set	3430-0197	Set of four No. 3400-0073 Unitized Valve Assemblies: Consists of four each: O-ring (Ref. A), Valve Seat (Ref. B), Valve Poppet (Ref. C), Valve Spring (Ref. D), and Valve Spring Retainer (Ref. E)

Ref. No.	Qty. Req'd.	Part No.	Description
19	1	0108-5300C	Body (Cast Iron)
21	1	2405-0006	Grease Fitting
22	1		Hollow Shaft Sub-Assembly (see listing above)
24	2	2230-0017	Set Screws for Hollow Shaft
25	1	1610-0011	Spline Key for Hollow Shaft
26	1		Solid Shaft Sub-Assembly (see listing above)
27	1	1610-0007	Spline Key for Solid Shaft
28	1	2130-0007	Shield
29	2	2008-0001	Main Bearing
30	2	1810-0013	Retaining Ring (shaft)
31	1	1820-0025	Retaining Ring (housing)
32	1	1510-0041	Mounting Base for Solid Shaft Models
33	1	3420-0030	Torque Arm Kit for Hollow Shaft Models - Consists of No. 2820-0035 Torque Arm, No. 1450-0003 Bumper and two No. 2210-0064 Bolts
34	2	2270-0097	Washer (Model 5322 only)

Spec Pumps 53702 and 53703

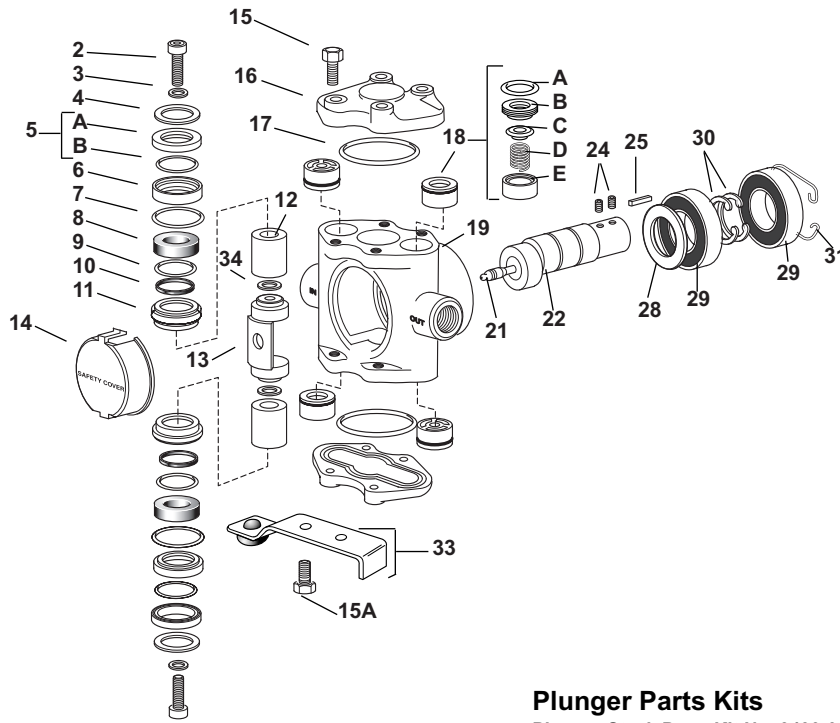

NOTE: When ordering parts, give QUANTITY, PART NUMBER, DESCRIPTION, and COMPLETE MODEL NUMBER. Reference numbers are used ONLY to identify parts in the drawing and are NOT to be used as order numbers.

Plunger Parts Kits

Plunger Stack Parts Kit No. 3430-0291

Consists of two each of the following parts:
 No. 1440-0010-6 Seal Rings, No. 1440-0037 Guides, No. 1720-0064 O-rings, No. 1720-0079 O-rings, No. 2150-0027 Seal Assemblies, No. 2220-0039 Socket Head Cap Screws, No. 2270-0042 Washers, and No. 2270-0051 Washers.

Plunger Parts Kit No. 3430-0292

Consists of one No. 3430-0291 Plunger Stack Parts Kit and two No. 3500-0036 Plungers.

Crankshaft Assemblies

Spec Pump No. 53702

Hollow Shaft Sub-Assembly No. 5501-5318

Consists of one No. 0550-5318 Crankshaft, one No. 2007-0029 Cam Bearing, one No. 2405-0006 Grease Fitting Assembly, one No. 1610-0011 Key, two No. 2230-0017 Set Screws.

Hollow Shaft Assembly No. 5500-5318

Consists of one No. 5501-5318 Crankshaft Sub-Assembly, two No. 1810-0013 Retaining Rings, two No. 2008-0001 Main Bearings, one No. 2130-0007 Bearing Shield.

Spec Pump No. 53703

Hollow Shaft Sub-Assembly No. 5501-5320

Consists of one No. 0551-5320 Crankshaft, one No. 2007-0029 Cam Bearing, one No. 2405-0006 Grease Fitting Assembly, one No. 1610-0011 Key, two No. 2230-0017 Set Screws.

Hollow Shaft Assembly No. 5500-5320

Consists of one No. 5501-5320 Crankshaft Sub-Assembly, two No. 1810-0013 Retaining Rings, two No. 2008-0001 Main Bearings, one No. 2130-0007 Bearing Shield.

Ref. No.	Qty. Req'd.	Part No.	Description
2	2	2220-0039	Socket Head Cap Screw
3	2	2270-0042	Washer
4	2	1830-0056	Retainer
5	2	2150-0027	Seal Assembly: Consists of one No. 2150-0049 Seal (Ref. A) and one No. 1440-0061 Support Ring (Ref.B)
6	2	1830-0054	Seal Retainer
7	2	1720-0079	O-ring for Seal Retainer
8	2	1440-0037	Guide
9	2	1720-0064	O-ring for Seal Ring
10	2	1440-0010	Seal Ring
11	2	1830-0053	Guide Retainer
12	2	3500-0036	Plunger
13	1	0504-5300	Connecting Rod
14	1	0608-5300	Safety Cover
15	8	2210-0063	Cylinder Head Bolt
15A	2	2210-0064	Extra Long Cylinder Head Bolt for torque arm
16	2	0201-5300C	Cylinder Head (Cast Iron)
17	2	1720-0038	O-ring for Cylinder Head

Ref. No.	Qty. Req'd.	Part No.	Description
18	1 Set	3430-0197	Set of four No. 3400-0073 Unitized Valve Assemblies: Consists of four each: O-ring (Ref. A), Valve Seat (Ref. B), Valve Poppet (Ref. C), Valve Spring (Ref. D), Valve Spring Retainer (Ref. E)
19	1	0108-5300C	Body (Cast Iron)
21	1	2405-0006	Grease Fitting
22	1	****	Hollow Shaft Sub-Assembly (See listing above for description)
24	2	2230-0017	Set Screws for Hollow Shaft
25	1	1610-0011	Spline Key for Hollow Shaft
28	1	2130-0007	Shield
29	2	2008-0001	Main Bearing
30	2	1810-0013	Retaining Ring (shaft)
31	1	1820-0025	Retaining Ring (housing)
33	1	3420-0030	Torque Arm Kit: Includes (1) No. 2820-0035 Torque Arm, (1) No. 1450-0003 Bumper and (2) No. 2210-0064 Bolts.
34	2	2270-0097	Washer

Models 5324C and 5324C-H

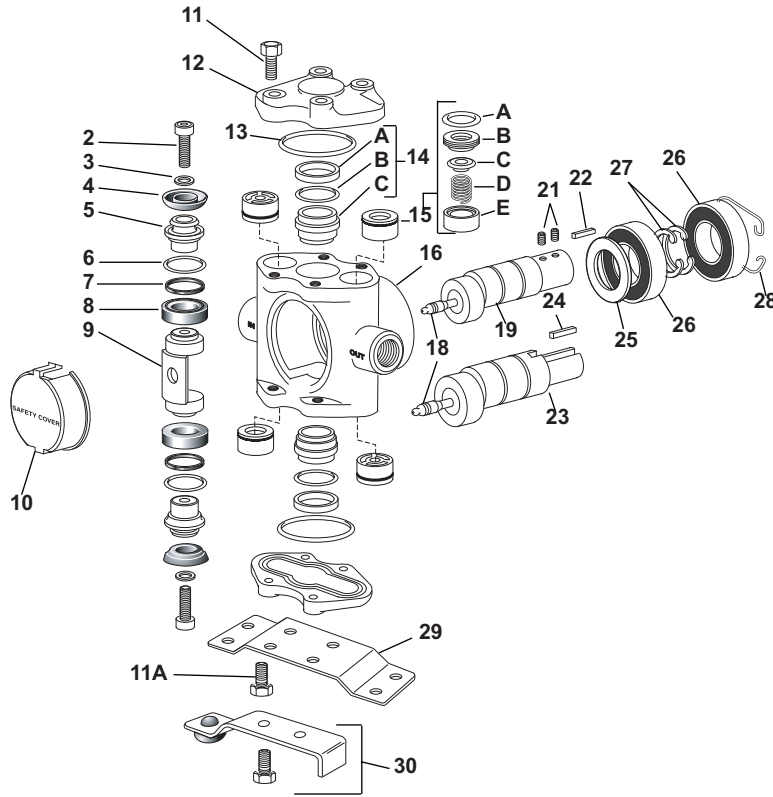

Piston Parts Kit

Piston Stack Parts Kit No. 3430-0191

Consists of two each of the following parts: No. 2220-0012 Cap Screw (Ref. 2), No. 2270-0011 Washer (Ref. 3), No. 2150-0047 Cup (Ref. 4), No. 1720-0029 O-ring (Ref. 6), No. 1440-0059 Seal Ring (Ref. 7) and No. 1440-0060 Guide (Ref. 8).

Crankshaft Assembly Kits

Model 5324C

Solid Shaft Sub-Assembly No. 5001-5321

Consists of one each of the following parts: No. 0500-5321 Crankshaft, No. 1600-0014 Crankpin Retainer, No. 2007-0029 Cam Bearing, No. 2405-0006 Grease Fitting Assembly, No. 1610-0007 Key.

Model 5324C-H

Hollow Shaft Sub-Assembly No. 5501-5321

Consists of one No. 0550-5321 Crankshaft, one No. 1600-0014 Crankpin Retainer, one No. 2007-0029 Cam Bearing, one No. 2405-0006 Grease Fitting Assembly, one No. 1610-0011 Key, two No. 2230-0017 Set Screws.

Hollow Shaft Assembly No. 5500-5321

Consists of one No. 5501-5321 Crankshaft Sub-Assembly, two No. 1810-0013 Retaining Rings, two No. 2008-0001 Main Bearings, one No. 2130-0007 Bearing Shield.

Ref. No.	Qty. Req'd.	Part No.	Description
2	2	2220-0012	Piston Cap Screw
3	2	2270-0011	Washer
4	2	2150-0047	Cup
5	2	1830-0092	Cup Holder
6	2	1720-0029	O-Ring
7	2	1440-0059	Seal Ring
8	2	1440-0060	Guide
9	1	0500-5324	Connecting Rod
10	1	0608-5300	Safety Cover
11	*	2210-0063	Cylinder Head Bolt (8 required for Hollow Shaft Pump; 4 required for top cylinder head ONLY on Solid Shaft Pump)
11A	4	2210-0064	Extra Long Cylinder Head Bolt for securing mounting base to Solid Shaft Pump
12	2	0201-5300C	Cylinder Head (Cast-Iron)
13	2	1720-0038	O-Ring
14	1	3430-0210	Ni-Resist Cylinder Sleeve Assembly: Consists of two each of No. 1830-0033 Retainer (Ref. A), No. 1720-0079 O-ring (Ref. B), and No. 3550-0028 Sleeve (Ref. C)

Ref. No.	Qty. Req'd.	Part No.	Description
15	1 set	3430-0197	Set of four No. 3400-0073 Unitized Valve Assemblies: Consists of four each: O-ring (Ref. A), Valve Seat (Ref. B), Valve Poppet (Ref. C), Valve Spring (Ref. D), Valve Spring Retainer (Ref. E)
16	1	0108-5300C	Body (Cast Iron)
18	1	2405-0006	Grease Fitting
19	1		Hollow Shaft Sub-Assembly (see listing above)
21	2	2230-0017	Set Screw for Hollow Shaft Pump
22	1	1610-0011	Key for Hollow Shaft Pump
23	1		Solid Shaft Sub-Assembly (see listing above)
24	1	1610-0007	Key for Solid Shaft Pump
25	1	2130-0007	Shield
26	2	2008-0001	Bearing
27	2	1810-0013	Retaining Ring (shaft)
28	1	1820-0025	Retaining Ring (housing)
29	1	1510-0041	Mounting Base for Solid Shaft Pump
30	1	3420-0030	Torque Arm Kit for Hollow Shaft Pump: Consists of (1) No. 2820-0035 Torque Arm, (1) No. 1450-0003 Bumper and (2) No. 2210-0064 Bolts

Accessory

HYPRO SERIES Liquid Injector Heads

3396-0006

3396-0014

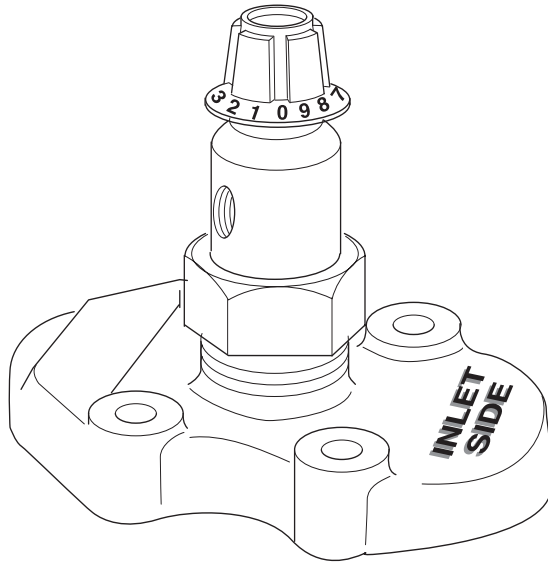

Model 3396-0014

for Hypro Series 5300 cast iron pumps with suffix "X"

Model 3396-0006

for Hypro Series 5321 and 5324 cast iron pumps

SPECIFICATIONS

Cylinder Head — Cast iron with special flow

Inlet Port — 1/8" NPT (F) can be positioned to face any direction.

Brass Valve Stem — Needle-type metering, for accurate mixing of injected solution and liquid being pumped.

Unitized Valve Assembly — Stainless steel valve spring, ball and valve seat. Nylon spring retainer.

Control Knob — Calibrated with 9 steps in a 360° turn. Can be rotated up to three times.

Maximum Temperature — 140° Fahrenheit (60° C)

Net Weight — Model 3396-0014: 1 lb. 8 oz. (594.8 g.)
Model 3396-0006: 1 lb. 12 oz. (793.2 g.)

The Hypro Series 3396 Liquid Injector Head mounts directly on the pump, replacing the regular cylinder head. It feeds solution directly into the pump, mixing it with the regular pump flow. No internal pump parts are removed or disassembled to install the injector.

Amount of solution injected is regulated by a needle valve and adjusted by a calibrated control knob. Positive seating ball-type check valve prevents back flow of liquid from the pump into the injector. This allows application of soap, detergent and other solutions through the injector, then by closing the injector supply, followed by a clear water rinse through the pump.

The 1/8" NPT (F) inlet port can be positioned to face any direction. A built-in flow regulator channel in the cylinder head compensates for various inches of mercury (127 mm/Hg), up to a maximum incoming pressure of 20 psi (137.8 kPa). NOTE: If incoming pressure is higher, a pressure regulator must be used.

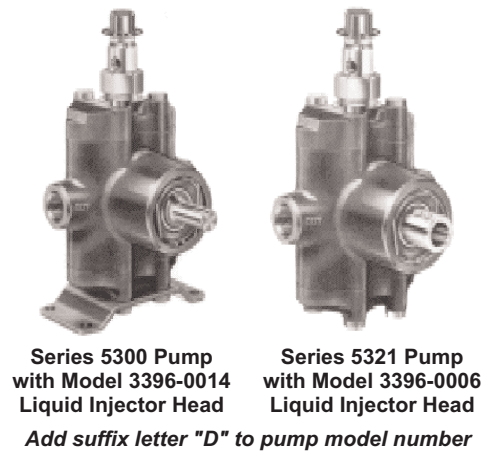

HYPRO PISTON PUMP	MODEL 5320 (2 GPM)			MODEL 5330 (3 GPM)			MODEL 5321 (2.2 GPM)			MODEL 5324 (2.9 GPM)		
Pressure at Pump Outlet	500 psi			500 psi			1000 psi			800 psi		
Pump Inlet Conditions	5" Hg	10 psi	20 psi	5" Hg	10 psi	20 psi	5" Hg	10 psi	20 psi	5" Hg	10 psi	20 psi
Maximum Water Injected Per Minute	9 oz.	6 oz.	5 oz.	10 oz.	9 oz.	8 oz.	11-1/2 oz.	10-1/2 oz.	8 oz.	17 oz.	15-1/2 oz.	13 oz.
HYPRO PISTON PUMP	MODEL 5320 (7.57 L/min.)			MODEL 5330 (11.4 L/min.)			MODEL 5321 (8.3 L/min.)			MODEL 5324 (11 L/min.)		
Pressure at Pump Outlet	3.45 MPa			3.45 MPa			6.9 MPa			5.52 MPa		
Pump Inlet Conditions	127 mm/ Hg	68.9 kPa	137.8 kPa	127 mm/ Hg	68.9 kPa	137.8 kPa	127 mm/ Hg	68.9 kPa	137.8 kPa	127 mm/ Hg	68.9 kPa	137.8 kPa
Maximum Water Injected Per Minute	266.4 ml	177.6 ml	148 ml	266.4 ml	177.6 ml	148 ml	266.4 ml	177.6 ml	148 ml	266.4 ml	177.6 ml.	148 ml

DIMENSIONS

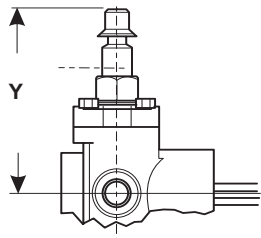
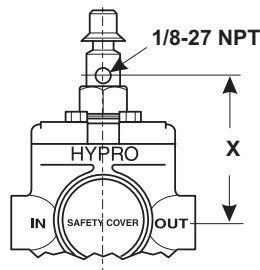

X=3-13/16"	Y=5-5/16"
X=96.8 mm	Y=135 mm

X=3-3/16"	Y=5-11/16"
X=106.4 mm	Y=144.5 mm

INSTALLATION: IMPORTANT

Liquid injector cylinder head **MUST** be installed with the flow regulator channel over the inlet valve of the pump. "Inlet Side" is cast on the cylinder head of injector for ease in identification.

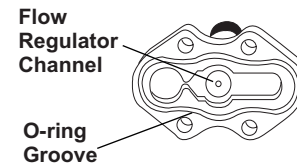

TO ADJUST THE POSITION OF THE INLET PORT

To change the position of the liquid injector inlet port, loosen the retainer nut (Ref. 5), and rotate injector body (Ref. 4) until the opening is in the desired position. It is important that the retainer nut be fully tightened to properly compress the o-ring seal (Ref. 3) against the valve assembly (Ref. 2)

OPERATION

Before using the injector, make sure the retainer nut is tightened securely. **NOTE:** The "Inlet Port" on the body indicates the position of the dial setting (closed position is zero). The larger the number, the more flow is allowed. **DO NOT** rotate the control knob more than three complete turns.

MAINTENANCE

If opening around needle valve stem becomes clogged, clean the valve stem and passage way with warm soapy water. Rotate the control knob assembly counter-clockwise (which includes the control knob and needle valve stem) until it can be lifted out of the body. Inspect the valve stem o-ring and replace if necessary. Install the control knob assembly by pushing down firmly on the knob and turning clockwise until it is in the closed position. Set the injector to the desired setting.

PARTS LIST

Model No. 3396-0014, 3396-0006 Liquid Injector Heads

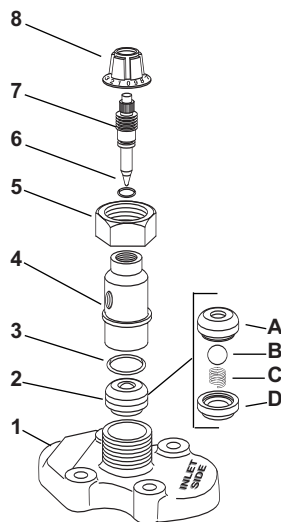

Ref. No.	Quantity Required	Part Number	Description
1	1	0257-5300C	Cylinder Head for Model 3396-0014 (cast iron)
1	1	0254-5300C	Cylinder Head for Model 3396-0006 (cast iron)
2	1	3400-0098	Unitized Valve Assembly
3	1	1720-0029	O-ring
4	1	3200-0027	Body
5	1	3240-0006	Retainer Nut
6	1	1720-0033	O-ring
7	1	3220-0016	Needle Valve Stem
8	1	2802-0002	Calibrated Adjustment Control Knob

NOTES

NOTES

Limited Warranty on Hypro Pumps and Other Hypro Products

Hypro warrants to the original purchaser of its products (the "Purchaser") that such products will be free from defects in material and workmanship under normal use for the period of one (1) year for all products except: oil crankcase plunger pumps will be free from defects in material and workmanship under normal use for the period of five (5) years, and accessories will be free from defects in material and workmanship under normal use for the period of ninety (90) days. In addition, Hypro warrants to the purchaser all forged brass pump manifolds will be free from defects in material and workmanship under normal use and from damage resulting from environmental conditions for the life of the pump.

"Normal use" does not include use in excess of recommended maximum speeds, pressures, vacuums and temperatures, or use requiring handling of fluids not compatible with component materials, as noted in Hypro product catalogs, technical literature, and instructions. This warranty does not cover freight damage, freezing damage, normal wear and tear, or damage caused by misapplication, fault, negligence, alterations, or repair that affects the performance or reliability of the product.

THIS WARRANTY IS EXCLUSIVE. HYPRO MAKES NO OTHER WARRANTY, EXPRESS OR IMPLIED, INCLUDING BUT NOT LIMITED TO ANY WARRANTY OF MERCHANTABILITY OR FITNESS FOR A PARTICULAR PURPOSE.

Hypro's obligation under this warranty is, at Hypro's option, to either repair or replace the product upon return of the entire product to the Hypro factory in accordance with the return procedures set forth below. **THIS IS THE EXCLUSIVE REMEDY FOR ANY BREACH OF WARRANTY.**

IN NO EVENT SHALL HYPRO BE LIABLE FOR ANY INCIDENTAL OR CONSEQUENTIAL DAMAGES OF ANY KIND, WHETHER FOR BREACH OF ANY WARRANTY, FOR NEGLIGENCE, ON THE BASIS OF STRICT LIABILITY, OR OTHERWISE.

Return Procedures

All pumps or products *must* be flushed of *any* chemical (ref. OSHA Section 0910.1200 (d)(e)(f)(g)(h)) and hazardous chemicals *must* be labeled before being shipped* to Hypro for service or warranty consideration.

Hypro reserves the right to request a Material Safety Data sheet from the Purchaser for any pump or product Hypro deems necessary. Hypro reserves the right to "disposition as scrap" pumps or products returned which contain unknown substances, or to charge for any and all costs incurred for chemical testing and proper disposal of components containing unknown substances. Hypro requests this in order to protect the environment and personnel from the hazards of handling unknown substances.

For technical or application assistance, call the **Hypro Technical/Application number: 1-800-445-8360.**

To obtain service or warranty assistance, call the Hypro Service and Warranty number: 1-800-468-3428; or call the Hypro Service and Warranty FAX: (651) 766-6618.

Be prepared to give Hypro full details of the problem, including the following information:

1. Model number and the date and from whom you purchased your pump.
2. A brief description of the pump problem, including the following:
 - Liquid pumped. State the pH and any non-soluble materials, and give the generic or trade name.
 - Drive type (gas engine/electric motor; direct/belt drive; tractor PTO) and rpm of pump.
 - Temperature of the liquid and ambient environment.
 - Viscosity (of oil, or other than water weight liquid).
 - Suction lift or vacuum (measured at the pump).
 - Elevation from the pump to the discharge point.
 - Discharge pressure.
 - Size and material of suction and discharge line.
 - Size, type, and mesh of the suction strainer.
 - Type of spray gun, orifice size, unloader/relief valve.

Hypro may request additional information, and may require a sketch to illustrate the problem.

Contact the factory to receive a return material authorization before sending the product. All pumps returned for warranty work should be sent shipping charges prepaid to: HYPRO

Attention: Service Department
375 Fifth Avenue NW
New Brighton, Minnesota 55112



**Pentair Water
SPRAY GROUP**

375 Fifth Avenue NW • New Brighton, MN 55112
Phone: (651) 766-6300 • 800-424-9776 • Fax: 800-323-6496
www.hypropumps.com