



**Foam Control
Installation & Operation
Instructions**

**Aquis 1.5
Rev 5**

Unit Serial Number _____

Waterous, Arizona Operations
7612 North 74th Ave.
Glendale, Arizona 85303
623-979-3398
Fax: 623-979-6949
www.waterousco.com

Warnings, Cautions, and Notes

Warning: A warning alerts you to a procedure, practice or condition that may result in death or long term injury to personnel or destruction of equipment.

Caution: A caution alerts you to a procedure or condition that may result in serious damage to equipment or its failure to operate as expected

Note: A note points out important information. Failure to read the note may not result in physical harm to personnel or equipment. It may waste time and money.

Revision History

Revision	Date Issued	Comments
-	11/15/2007	Initial Release
1	7/22/2010	Added Foam Cert
2	1/7/2011	Added Troubleshooting chart, updated Fig. 7
3	5/9/2011	Added Flow Tee drawing
4	7/15/2011	Changed OIT per ECR 260,
5	8/24/11	added oil fill details

Disclaimer: These instructions are guidelines only and in no way meant to be definitive. During installation, standard safety precautions and equipment should be used where appropriate. Because the tools used and the skill/experience of the installer can vary widely, it is impossible to anticipate all conditions under which this installation is made, or to provide cautions for all possible hazards. Proper installation is the responsibility of the purchaser. All bolts, setscrews, and belts must be checked prior to start-up AND after the initial operation. Damages due to poor installation are the responsibility of the installer.

Waterous reserves the right to make modifications to the system without notice

Table of Contents

SECTION 1.	SAFETY, Everyone's Concern	4
SECTION 2.	INSTALLATION PLANNING	5
SECTION 3.	PLUMBING COMPONENTS	7
A.	Motor / Pump Assembly	7
I.	Power Supply	9
II.	Motor / Pump	9
III.	Pump Maintenance	10
B.	Discharge Relief Valve	11
C.	Wye Strainer	11
D.	Flow Sensor	11
E.	Tee	12
F.	Drain Lines	12
G.	Inject / Bypass Valve	13
SECTION 4.	ELECTRICAL COMPONENTS	14
A.	Operator Interface Terminal (OIT)	15
B.	Flow Sensor	16
SECTION 5.	CALIBRATION AND SETUP	16
SECTION 6.	OPERATION	17
A.	Operating the System	17
B.	Manual Mode:	17
SECTION 7.	TROUBLESHOOTING CHART	21
SECTION 8.	DRAWINGS	23
SECTION 9.	PARTS LIST	27
SECTION 10.	CONDITIONAL 1-YEAR WARRANTY POLICY	28

Figure(s)

Figure 1	Motor / Pump assembly	8
Figure 2	Terminal block locations	9
Figure 3	Small Terminal Block	10
Figure 4	Flow Tee	12
Figure 5	Flow sensor	16
Figure 6	1.5 OIT	17
Figure 7	Basic System Schematic	23
Figure 8	Control Panel Cutout	24
Figure 9	Aquis Z Bracket Mount Bolt Pattern	25
Figure 10	Aquis Flow Tees	26

SECTION 1. SAFETY, Everyone's Concern

Please read all of the following safety precautions and follow carefully. They are important to the prevention of personal injury or damage to the equipment.

1. Do not pump at pressures higher than the maximum recommended pressure. [400 psi (28 BAR)]
2. Do not permanently remove or alter any guarding devices or attempt to operate the system when these guards are temporarily removed.
3. Always disconnect the power source before attempting to service any part of the pump.
4. Release all pressure within the system before servicing any of its components.
5. Drain all concentrate and water from the discharge system before servicing any of its component parts.
6. Check all hoses for weak or worn conditions on a regular basis. Ensure that all connections and fittings are tight and secure.
7. Use only pipe, hose, and fittings from the foam pump outlet to the injector fitting, which are rated at or above the maximum pressure [400 psi (28 BAR) minimum] rating at which the water pump system operates.
8. Any electrical system has the potential to cause sparks during service. Take care to eliminate explosive or hazardous environments during service/repair.

Caution: Do not attempt to operate the system at or above a temperature of 160°F (71°C)

Ensure that the electrical source of power for the unit is the appropriate (12 or 24 volt, negative ground DC system, with a minimum current rating of at least 50 amps for 12 VDC or 30 amps for 24 VDC system) to the circuit breaker. A 50 amp re-settable circuit breaker is provided. See Figure 2. Only the Aquis system is protected by the circuit breaker.

Periodically inspect the pump and the system components. Perform routine preventive maintenance as required. Failure to perform routine maintenance may cause damage to the pump.

Read and understand "Operation" section before attempting to operate the unit.

Always disconnect the ground straps and control cables from the Operator Interface Terminal (OIT) or other Aquis equipment before electric arc welding at any point on the apparatus. Failure to do so will result in a power surge through the unit that could cause irreparable damage to the system components.

The cables shipped with each Aquis unit are tested at the factory. Improper handling and forcing connections can damage these cables which could result in other system damage.

This document explains how to set up and operate the Aquis Foam Control system.

SECTION 2. INSTALLATION PLANNING

The Waterous recommends that you spend time planning where and how you intend to install this unit in the equipment before beginning the actual installation.

Determine the locations of the components to be installed such as; foam tank, Motor / Pump Assembly, Flow Tee and Operator Interface Terminal (OIT).

- Locate the pump as close to the supply source as possible. Install it in a clean space where it will be easy to inspect and maintain. Allow room for checking the oil level, changing the oil, and general servicing.
- Try to place components in locations that require the least amount of cables, hoses and fittings.
- Position the Motor / Pump Assembly in an area that is protected from road debris and excessive heat buildup.
- It is recommended that the Motor / Pump Assembly be installed in an accessible compartment located in the vicinity of the Operator Interface Terminal (OIT) panel.
- Place the foam tank so that the refilling can be done safely.
- Most water tank manufacturers will build the foam tank into the booster tank.
- When specifying a integral foam tank, make sure provisions are made for installation of the optional low tank level sensor as well as foam suction connections and tank drainage according to NFPA.

Determine a location for the Operator Interface Terminal (OIT) on the operator panel of the equipment.

- Consider the routing path of the cable from the Operator Interface Terminal (OIT) to the Pump / Motor Driver Assembly.
- If necessary, order longer or shorter cable assemblies to suit the location demands.

Warning: Never attempt to cut or lengthen the molded cables. Cables can be daisy chained to obtain longer lengths.

Always disconnect the ground straps and control cables from the Operator Interface Terminal (OIT) or other Aquis equipment **“before”** electric arc welding or Plasma cutting, at any point on the apparatus. Failure to do so could result in a power surge through the unit that could cause irreparable damage to the electronic components.

Cautions: **Ensure Adequate Concentrate Supply.**
Aquis 1.5 - a minimum of 1/2 inch ID tubing

Safety Guards.

Follow all codes and regulations regarding installation and operation of the Aquis system.

Shut-Off Valves.

Never install shut-off valves between the pump and discharge pressure regulator, or in the regulator bypass line.

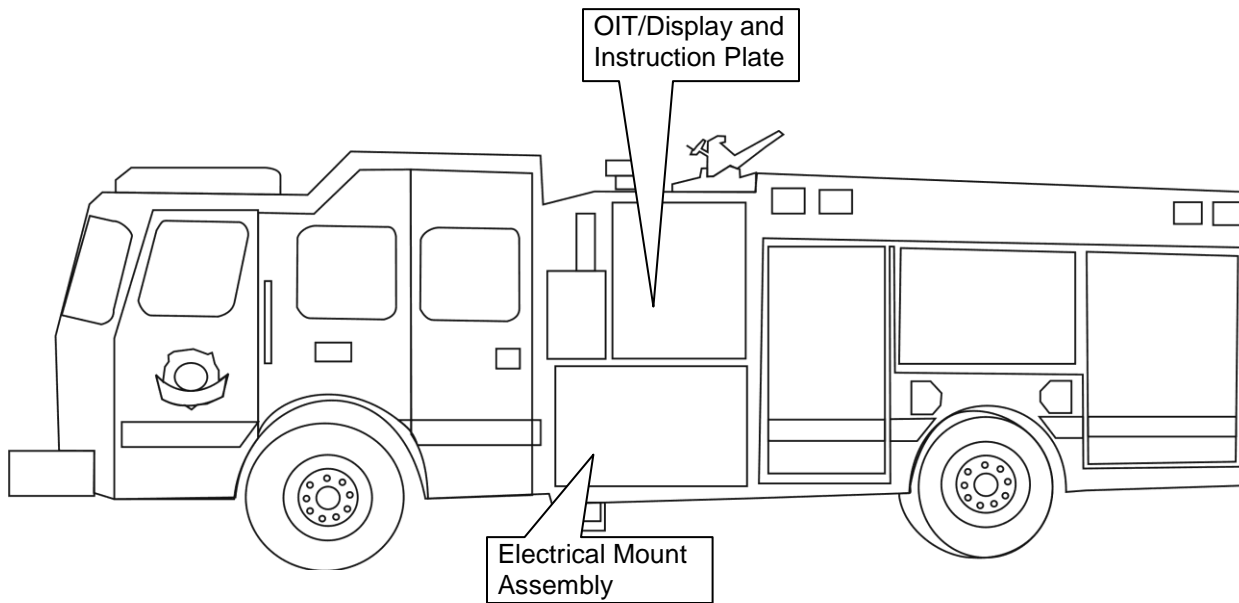

SECTION 3. PLUMBING COMPONENTS

A. Motor / Pump Assembly

The Motor / Pump Assembly must be mounted horizontally. The base must be anchored to a surface or structure that is rigid and of adequate strength to withstand the vibration and stresses of apparatus operation.

Warning: Remove shipping cap from oil fill and replace with vented cap (supplied)

Flexible hose is required to make the hose connections from the Motor / Pump Assembly to the foam tank. This hose must be rated for suction.

DO NOT hard pipe the system.

Consider access requirements for checking the foam pump. Be sure the foam concentrate hoses can be properly routed to the inlets and outlets on the foam pump.

Foam concentrates should gravity feed to the foam pump inlet from the foam tank. However the systems are capable of drafting up to 1 meter vertically. The Motor / Pump Assembly must be mounted in an area to avoid excessive exhaust system heat buildup.

Protect the hoses and wiring to prevent chafing and abrasion during operation of the foam system.

Protect the Motor / Pump Assembly from excessive road spray and debris. Although the system is sealed and designed to be resistant to the harsh environment of fire fighting apparatus, a protected compartment with easy operator access is the recommended installation location.

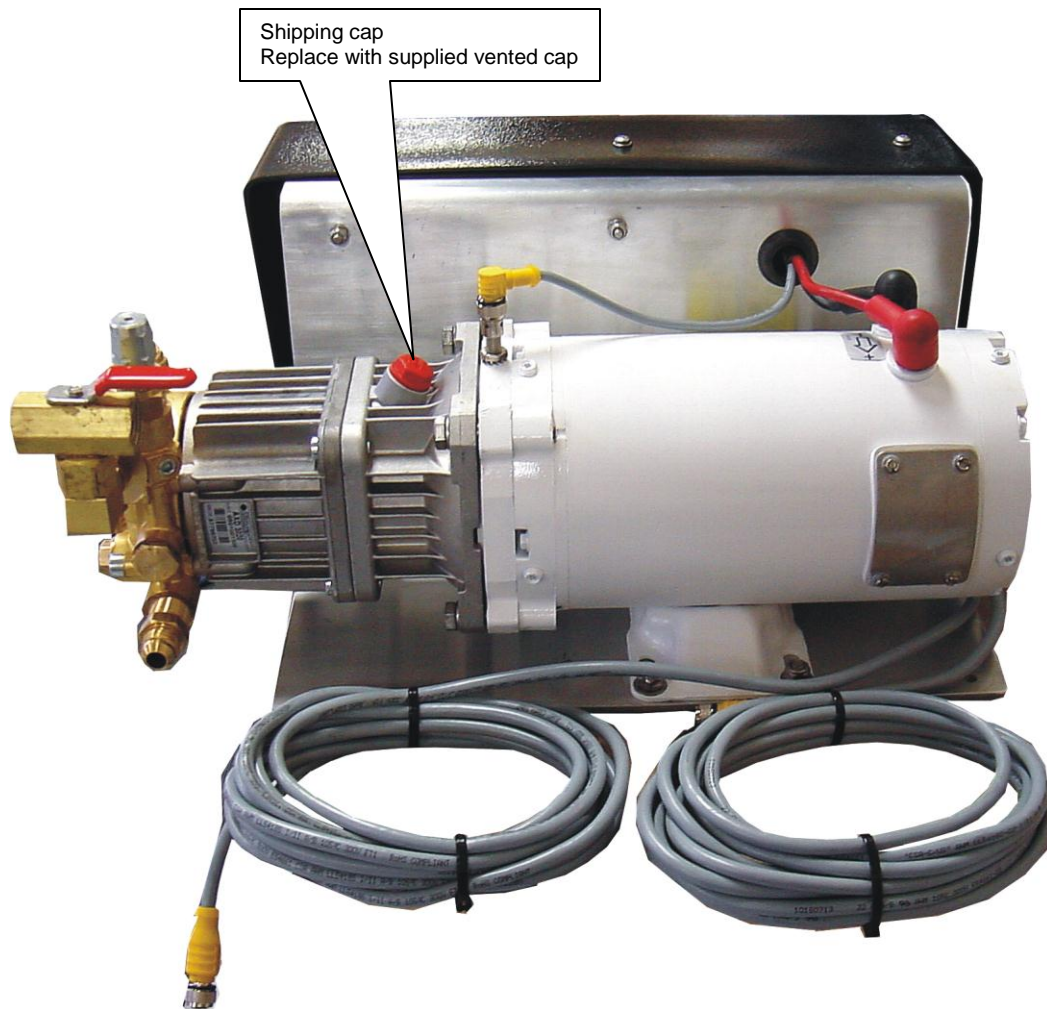

Figure 1 Motor / Pump assembly

The circuit breaker (provided, Figure 2) is used to connect the input power.

Make sure you provide adequate electrical power (50 amps minimum for 12 VDC systems or 30 amps for 24 VDC systems) from the battery. Use 8 AWG (minimum) wire directly to the battery or battery switch. Long wire runs may require 6 or 4 AWG wire for proper operation.

Recommended wire sizes	
Wire Size	Wire Length (approx.)
8 awg	10-20 feet
6 awg	20 feet to 30 feet
4 awg	30 feet or more

I. Power Supply

Electrical devices can be easily damaged by a weak or erratic power supply. The better the power supply, the better the Aquis system will perform. At maximum output, the Aquis system can draw 50 amps at 12 VDC or 30 amps at 24 VDC.

Connect the ground lead from the chassis frame or the negative battery terminal. Use the same size wire as the power lead. A good clean ground should always be provided for electronic components. A grounding stud is provided on all Aquis mounting brackets (See Fig. 2 below).

DO NOT connect the main power leads to small leads that are supplying some other device such as a light bar or siren.

CAUTION: Be careful not to damage or short circuit the wires leading to the circuit breaker. Only the Aquis system is protected by the circuit breaker.

II. Motor / Pump

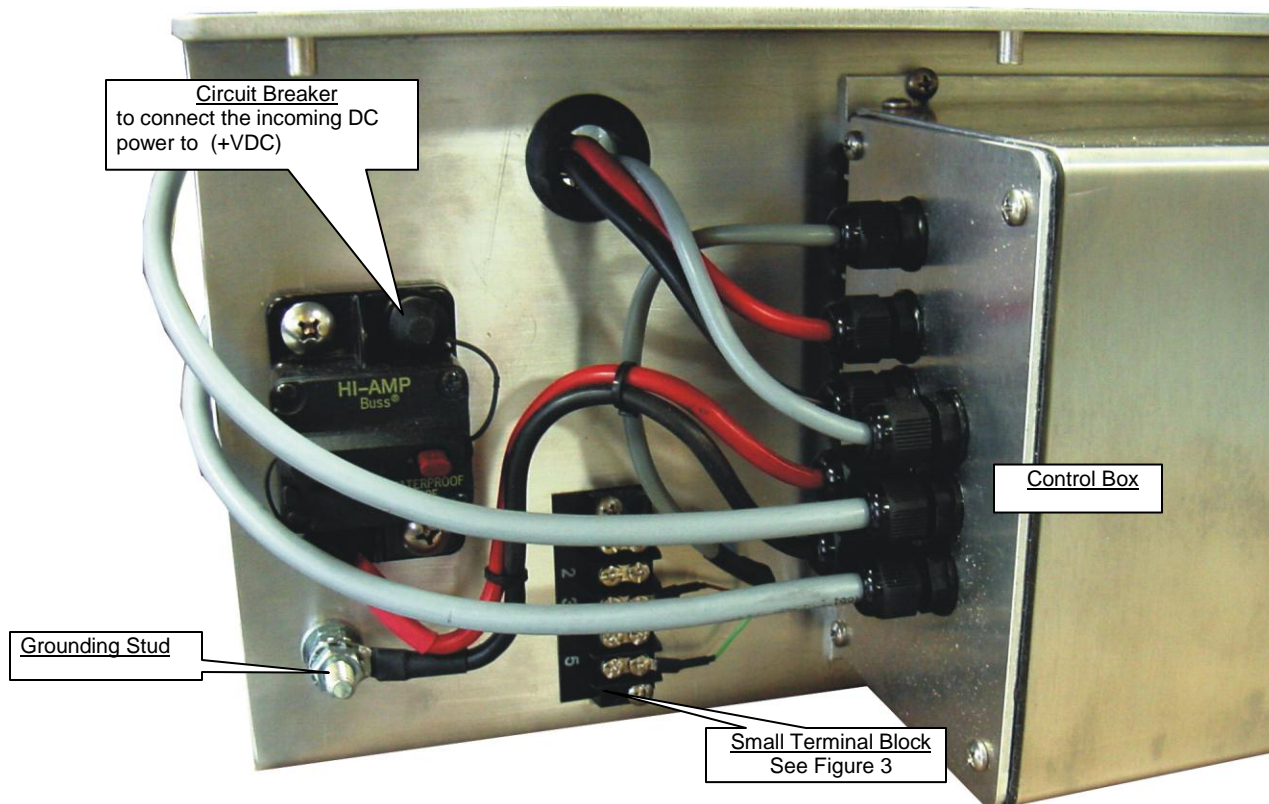

Figure 2 Terminal block locations

Note: There are no user serviceable parts inside the Control Box. Opening the Control Box will void the warranty.

All cables will come with a new Control box.

TANK SCHEMATIC

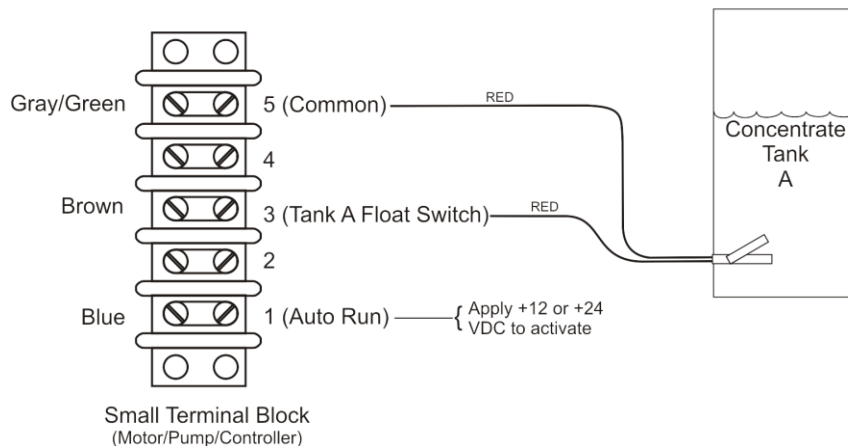
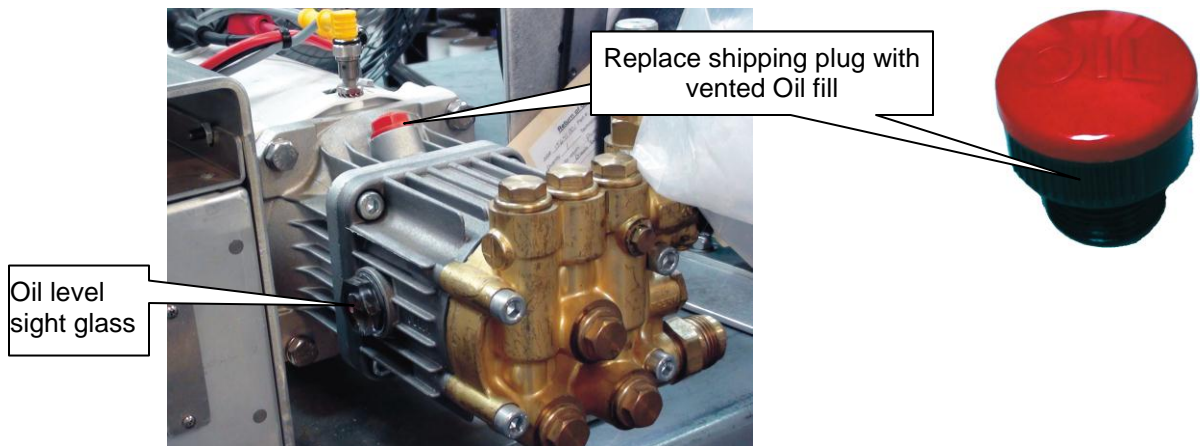

Figure 3 Small Terminal Block

III. Pump Maintenance

a) Daily



Check the oil level and the condition of the oil. The oil level should be visible in the center of the sight glass. (Red Dot)

Use the appropriate pump oil or equivalent, motor oil for the application (SAE 30, non-detergent oil).

Manufacturer's recommendations

OPERATION	Every 8 hours	Every 500 hours	Every 1500 hours
Check oil level	X		
Check tubes-fittings		X	
Check & clean inlet filter		X	
Control pump connection to the engine		X	
Change oil		X –First change	X
Check suction/delivery valves			X
Check pump bolt and nut setting			X
Check regulation valve			X

b) Periodically

Change the oil after the first 500 hours of operation, and every 1500 operating hours thereafter. When changing, all oil and accumulated sediment will need to drain out of fill port.

-
- Caution:**
- **DO NOT** turn the drive shaft while the oil reservoir is empty.
 - Protect the pump from freezing.
-

B. Discharge Relief Valve

The discharge relief valve is installed on the outlet port of the foam concentrate pump. It is provided to protect the pump from excessive pressures. The relief valve is factory set at 450 psi [31 BAR].

C. Wye Strainer

The line strainer provided with the unit has 1/2 inch NPT female threaded ports will need to be installed, in-line, between the foam supply tank and the foam pump. The hose from the foam tank should have adequate wall stiffness to withstand the vacuum of the foam pump while it is operating.

NOTE: If a pressurized water flush from one of the discharges is incorporated, the plumbing and line strainer exposed to this pressure must be rated at or above the operating pressure of all other discharge plumbing components.

D. Flow Sensor

The flow sensor (Figure 5) measures the water flow through the system and sends the information to the Control Box.

The flow sensor requires that the amount of turbulence be as low as possible. Excessive turbulence produces unstable and inaccurate flow readings. The following installation guidelines will help attain the best readings and maintain accuracy of the displayed value.

- a. The standard and minimum of 5x the pipe diameter of straight run pipe without any fittings is preferred upstream of the flow sensor. 10 times is even better — the longer the straight run, the lower the turbulence.
- b. The downstream plumbing of the flow sensor is not critical; but again, straight runs without fittings help maintain accurate flow readings.
- d. Last, try to mount the flow sensor in a position that is accessible for routine inspection and maintenance.

E. Tee

Aquis is supplied with one Flow Tee.

In horizontal runs, the tee / flow meter should be mounted upright.

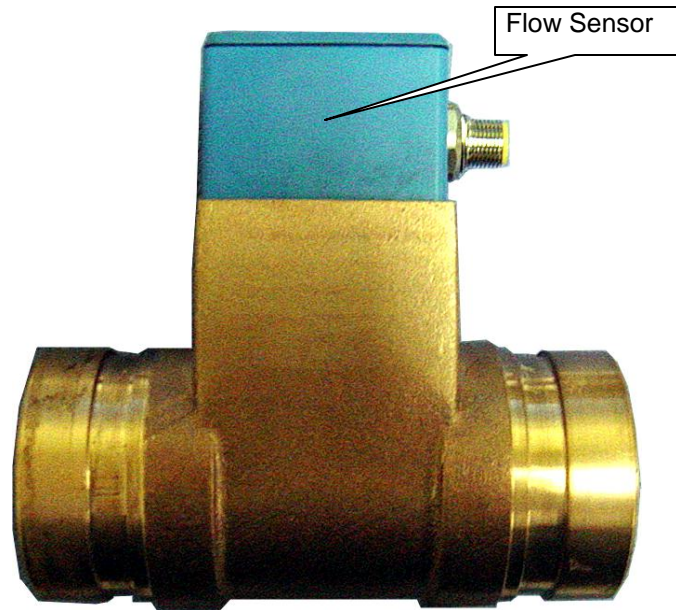

Figure 4 Flow Tee

F. Drain Lines

On apparatus with multiple drain lines, the drains from the foam solution discharge line should not be piped into a multi drain system before the check valves. The standard multi drain system from most manufacturers will allow cross talk between the drain lines and the apparatus water tank, resulting in contamination of the water tank with foam. A separate drain system should be provided for foam solution piping to prevent contamination of the water tank and fire pump.

G. Inject / Bypass Valve

The Inject/Bypass valve is mounted on the discharge side of the foam pump. This valve shall be accessible by the pump operator during normal operations. The valve is a 3-way directional valve that selects where the output of the foam pump will go.

Check to make sure the valve is installed properly. Look at the ports as you move the handle, the flow should go from the center port to each of the other ports.

The hose and fittings from the Inject port to the foam injector fitting should have minimum 3/8 inch inside diameter and be rated at 400 psi [28 BAR] minimum working pressure or maximum discharge pressure of the fire pump.

The hose from the Bypass port may have a lower pressure rating since it is plumbed to the atmosphere and will not receive high pressures. This hose is used for pumping the concentrate into a container to empty the tank or to assist in priming of the foam pump. The hose from the Bypass port must be long enough to reach a container outside the truck. This hose may be coiled for storage when not in use.



SECTION 4. ELECTRICAL COMPONENTS

Warnings:

Complete molded cable sets are provided with each Aquis system to make all the necessary connections.

The cables and receptacles are keyed so they only go in the correct receptacle and they can only go in one way.

DO NOT FORCE MISMATCHED CABLE CONNECTIONS. The system can only perform when the electrical connections are sound, so make sure each one is correct.

DO NOT hook up the main power cables until all of the connections are made to each of the electrical components. The last connection should be the power cable to the foam pump/motor base assembly.

DO NOT cut molded cables.

Make sure you provide at least 60 amps of electrical power for 12 VDC systems or 30 amps for 24 VDC systems from the battery to the main power terminal. Use 8 AWG (minimum) wire directly to the battery or battery switch.

This system is designed for either 12 or 24 volt negative ground direct current systems only.

Use care when installing molded cables. Count pins before connecting. Bent pins caused by improper hookup can prevent proper operation even when cables are reattached properly.

If the cable connection seal washer is missing or damaged, water can enter the connector and cause corrosion of the pins and terminals that will cause system failure.

The cables shipped with each Aquis unit are tested at the factory with that unit. Improper handling and forcing connections can damage these cables which could result in other system damage.

Always disconnect the ground straps and control cables from the Operator Interface Terminal (OIT) or other Aquis equipment "**before**" electric arc welding at any point on the apparatus. Failure to do so may result in a power surge through the unit that could cause irreparable damage to the system components.

A. Operator Interface Terminal (OIT)

Cables: 3 meter (standard)
Option: 3 or 6 meters

The Operator Interface Terminal (OIT) is designed to be mounted in the operator panel of the apparatus. The cutout needed for the Operator Interface Terminal (OIT), in the operator panel, is in back of this manual.

- The Operator Interface Terminal (OIT) is secured with four screws.

Note: Cables can be daisy chained to obtain longer lengths.



- The Operator Interface Terminal (OIT) requires 5 inches [127 mm] minimum from the back of the Operator Interface Terminal (OIT) panel to clear cables and connectors.
- Once the Operator Interface Terminal (OIT) is mounted, connect the proper cable from the Pump / Motor Driver Assembly to the 8 pin connector on the back of the Operator Interface Terminal (OIT).
- Make sure there is enough clearance behind the Operator Interface Terminal (OIT) assembly for the cables.
- There are no serviceable parts in the unit.

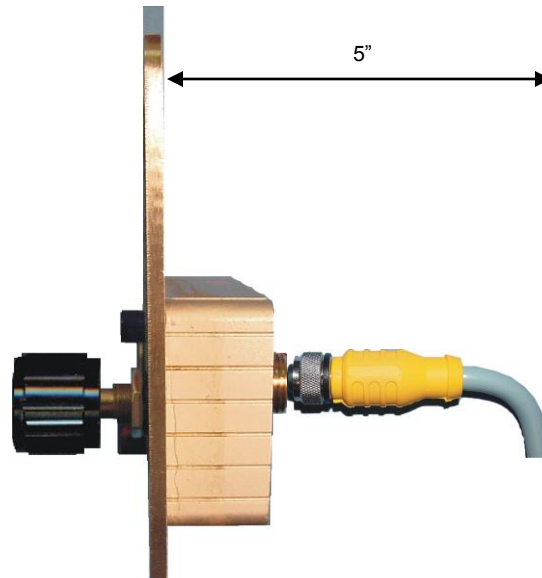

B. Flow Sensor

Cables: 3 meter (standard)
Option: 2 meter

A molded cable is supplied, which connects from the Flow sensor to the connector on the Pump / Motor Driver Assembly (see Figure 1).

Note: Cables can be daisy chained to obtain longer lengths.

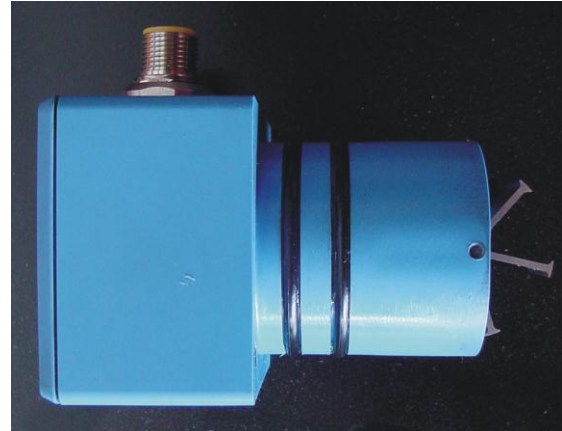

Figure 5 Flow sensor

SECTION 5. CALIBRATION AND SETUP

The Aquis system is able to be field calibrated using the control function button. Only water flow can be field set.

1. Turn the knob to "0" Foam %.
2. Press and hold the ON/OFF (RED) button for 6 seconds. Both LEDs will start oscillating between Red and Blue.
3. Release the button
4. Establish an accurate water flow of 50 GPM.
5. Press the ON/OFF (RED) button and the UPPER (Blue) LED will flash 3 times. Calibration is now saved.

System can also be calibrated using the Waterous Foam Controller program. Call for details.

Note: If there is an error during calibration, the LOWER (Red) LED will flash continuously until the Red button is pressed. In this case, the previous calibration will be maintained.

Flow Rate	Default Mix Percentage									
	.1%	.2%	.3%	.4%	.5%	.6%	.7%	.8%	.9%	1.0%
100	1	2	3	4	5	6	7	8	9	10
200	2	4	6	8	10	12	14	16	18	20
300	3	6	9	12	15	18	21	24	27	30
U.S. Gallons										

Highlighted numbers = ensure bucket is large enough to handle the volume

SECTION 6. OPERATION

A. Operating the System

1. Press ON/OFF button to start or stop system
2. Set foam % ratio by rotating the knob to the desired percentage.
3. UPPER (Blue) LED:
Solid ON: System standby
Slow flashing: System injecting
Fast flashing: MANUAL mode
4. LOWER (Red) LED:
Flashing: Concentrate in tank low, 2 min to shutdown
Solid ON: No concentrate, system shutdown



Figure 6 1.5 OIT

B. Manual Mode:

Press and hold the Red ON/OFF button for 2 seconds.
The UPPER (Blue) LED will flash at double rate.

Turn the knob clock-wise (to increase) or counter clock-wise (to decrease) the pump speed.

To stop manual mode, press the RED button once.

This page has been intentionally left blank.



**NFPA 1901 / 1906
Aquis 1.5 Foam System Certification**

Certified Manufacturer Type Test

OEM Certification Test

System

1 1/2" Thread or 2" Victaulic

Range	Water Flow	Range	Back Press. PSI	Foam %	Range	Foam Cap. (gpm)
Min	10	Min	0	.1	Min	.01
Max	325	Max	400	1	Max	1.3
Min	10	Max	400	.1	Min	.01
Max	325	Min	0	1	Max	1.7
Mid	160	Mid	150	.5	Mid	.8

Flowmeter

Range	Test Points	Sim Water Flow	Set Foam %	Range	Back Press. PSI	Range	Foam (gpm)
Min				Min		Min	
Mid				Mid		Mid	
Max				Max		Max	

2" Thread or 2 1/2" Victaulic

Range	Water Flow	Range	Back Press. PSI	Foam %	Range	Foam Cap. (gpm)
Min	20	Min	0	.1	Min	.02
Max	750	Max	400	1	Max	1.3
Min	20	Max	400	.1	Min	.02
Max	750	Min	0	1	Max	1.7
Mid	375	Mid	150	.5	Mid	1.5

Flowmeter

Range	Test Points	Sim Water Flow	Set Foam %	Range	Back Press. PSI	Range	Foam (gpm)
Min				Min		Min	
Mid				Mid		Mid	
Max				Max		Max	

2 1/2" Thread or 3" Victaulic

Range	Water Flow	Range	Back Press. PSI	Foam %	Range	Foam Cap. (gpm)
Min	30	Min	0	.1	Min	.03
Max	1200	Max	400	1	Max	1.3
Min	30	Max	400	.1	Min	.03
Max	1200	Min	0	1	Max	1.7
Mid	600	Mid	150	.5	Mid	1.5

Flowmeter

Range	Test Points	Sim Water Flow	Set Foam %	Range	Back Press. PSI	Range	Foam (gpm)
Min				Min		Min	
Mid				Mid		Mid	
Max				Max		Max	

Installer Certification:
Installed, Calibrated and Tested to Waterous AZ's Installation Recommendations and Purchaser's Performance Specifications

Tester: _____

Date: _____

Form: 482.1118

Issued: 7/21/10

This page has been intentionally left blank.

SECTION 7. TROUBLESHOOTING CHART

Aquis 1.5 Trouble shooting Chart		
Symptom	Probable Cause(s)	Corrective Action
1. Pump runs but produces no flow	Pump is not primed.	See Aquis 1.5 instructions page 17 for priming instructions
	No foam in tank	Fill foam tank
	Foam tank valve closed	Open valve
	Strainer plugged	Remove and clean strainer
	Check valves stuck in pump	Remove and clean check valves
2. Pump loses prime	Air leak in suction hose or inlet fittings.	Remove suction hose and test for leaks by pressurizing hose with water. Make sure thread sealant has been used on all fittings.
	Suction line is blocked, collapsed or too small.	Remove suction line and inspect it for debris lodged in hose.
		Replace line with larger if it is too small. Avoid all unnecessary bends. Do not kink hose.
3. Proportioner uses excessive amounts of concentrate (runs rich)	Speed sensor position incorrect.	Reset speed sensor position by referring to manual for instructions.
	Paddle wheel out of calibration.	Calibrate paddle wheel flow per instructions in manual.
	System is in manual mode.	Push foam button once.
	Foam pump out of calibration.	Contact Waterous for reprogramming.
4. Proportioner uses too little of concentrate (runs lean)	Paddle wheel out of calibration.	Calibrate paddle wheel flow per instructions in manual.
	Foam pump out of calibration.	Contact Waterous for reprogramming.
5. Pump runs full speed whenever the proportioner is either on or off	Faulty driver box.	Replace driver box.
6. Pump runs full speed whenever the proportioner is on	Poor ground to motor driver box on pump/motor	Make sure screws are tight and a good ground
7. Lights do not flash when system is turned on	The main power switch is not "ON".	Turn on the main power switch.
	Cables not correctly connected.	Inspect and secure connections.
	Inadequate ground.	Inspect and secure connections.
	Inadequate voltage.	Check voltage at system connection.
8. System is powered up and the Foam ON/OFF switch has been pressed but the foam pump doesn't run.	Control cable(s) defective.	Replace control cable(s)
	No water is flowing in any of the foam discharges.	Flow water through a foam capable discharge.
	Poor paddle wheel connection.	Check and reconnect.
	Paddle wheel obstructed.	Clear paddle wheel of debris.
9. Proportioner will not inject concentrate.	Paddle wheel not functioning.	Replace paddle wheel.
	Power not on.	Turn power on.
	Relief valve is set too low. (factory preset at 450 psi)	Reset relief to factory setting.
10. Poor foam quality during low water flows	Inject/Bypass valve in bypass position.	Move to inject position.
	Foam percentage is too low.	Increase foam percentage.
	Foam strainer restricted.	Remove and clean foam strainer.
11. Delay in foam showing at nozzle	Foam system calibration incorrect.	Re-calibrate.
	Low foam percentage and or low water flow.	Increase as needed.
	Proportioner not primed.	Prime proportioner per instructions.
	Foam inject check valve stuck open.	Replace foam inject check valve.
12. Red light stays solid on indicating no concentrate	Foam tank empty.	Fill foam tank.
	Float stuck on plunger—indicating tank is low.	Inspect and clean float switch.
	Low level sensor or wiring is inoperative.	Repair or replace defective components.
	Float installed incorrectly.	Reinstall float per instruction manual.
13. OIT fails to light up	Check master power on vehicle.	Turn on master power.
	Breaker switch has been tripped.	Reset breaker.
14. Blue OIT light fails to flash while flowing water through foam manifold	Inoperative paddle wheel	Test by removing paddle wheel and spinning by hand. Replace paddle wheel if light still fails to flash.
	Poor paddle wheel cable connections.	Check connections.
	Speed sensor position incorrect.	Reset speed sensor position by referring to manual for instructions.
15. Red light blinks continuously during calibration	Failed to sense water flow.	Recalibrate.

Aquis 1.5 Trouble shooting Chart

Symptom	Probable Cause(s)	Corrective Action
16. Foam in the water tank	Foam was poured in the wrong tank.	Flush water tank.
	Injection check valve stuck open.	Replace injection check valve.
	Foam manifold check valve fails to seal.	Inspect and clean or replace as necessary.
	Foam manifold drain is plumbed to master drain.	Isolate foam manifold drain.

SECTION 8. DRAWINGS

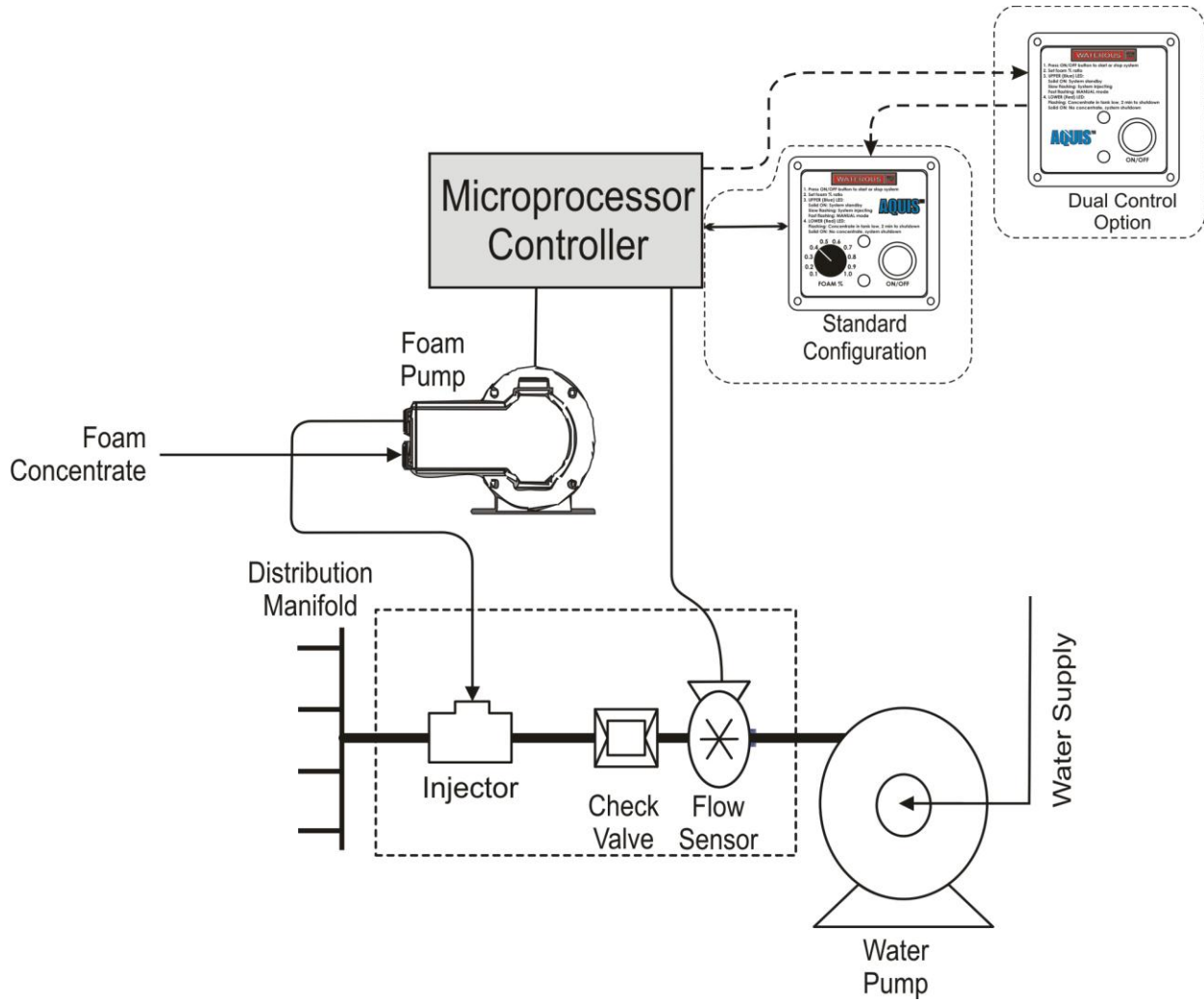
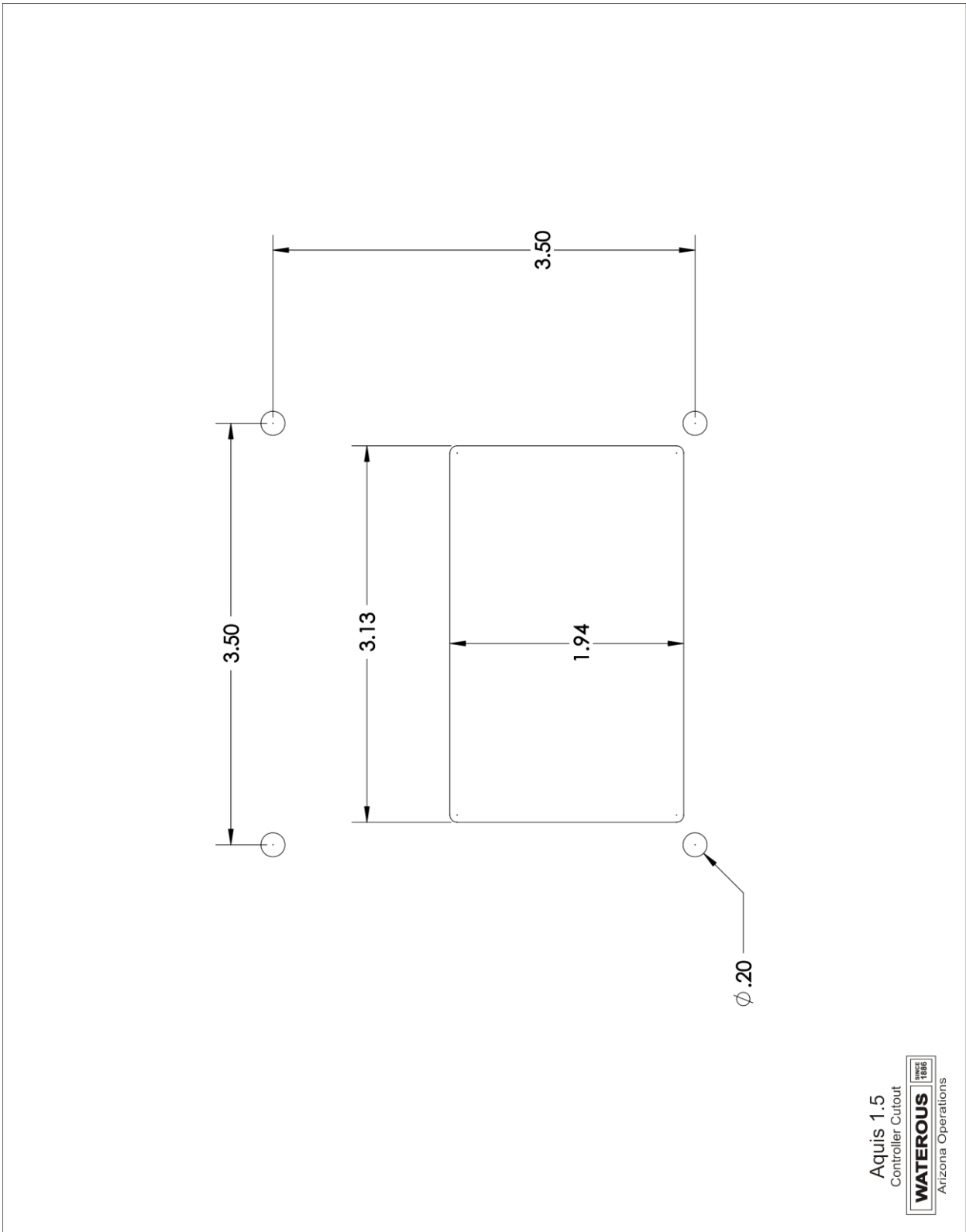

Figure 7 Basic System Schematic



Aquis 1.5
Controller Cutout

WATEROUS	since 1886
-----------------	---------------

Arizona Operations

Figure 8 Control Panel Cutout

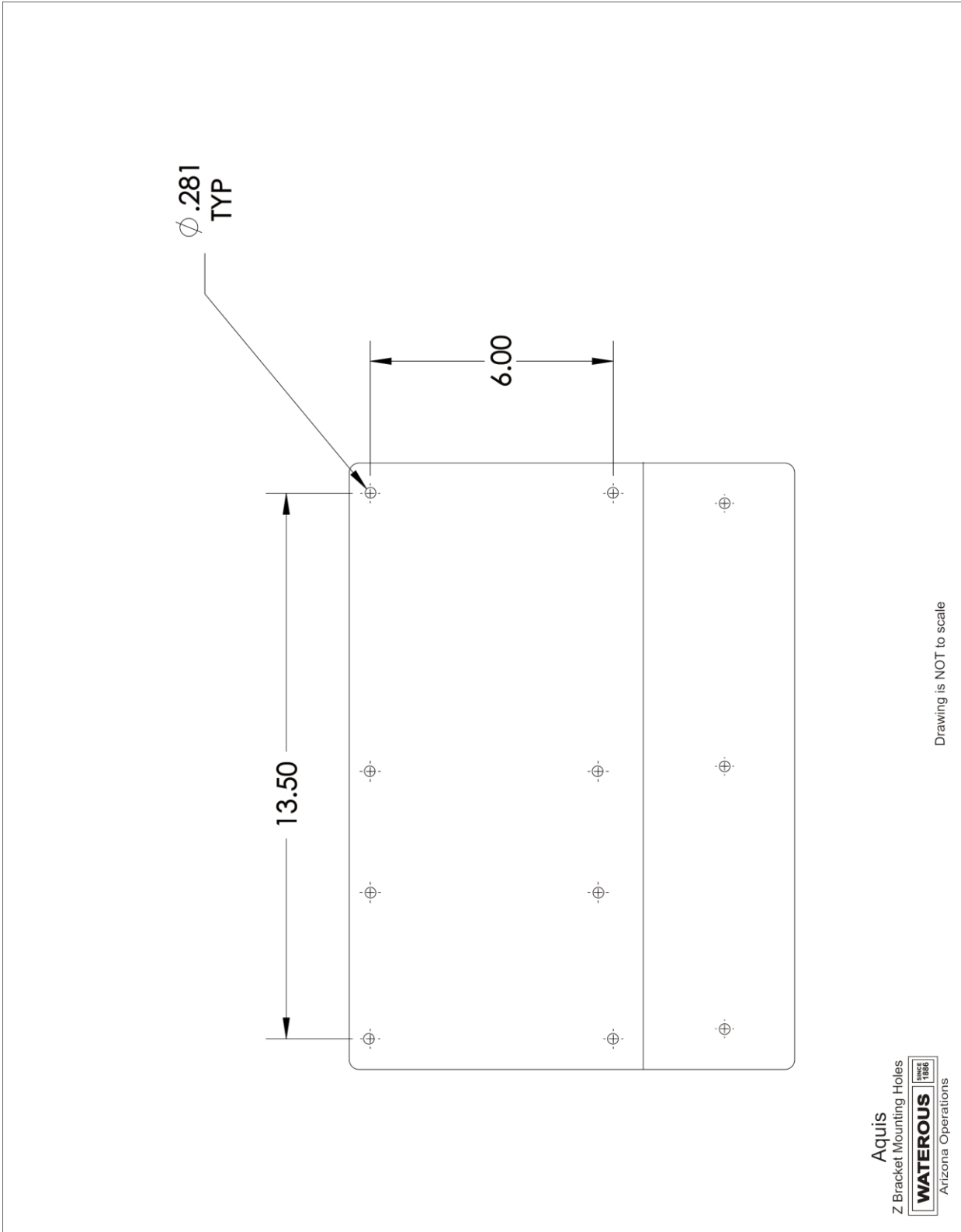
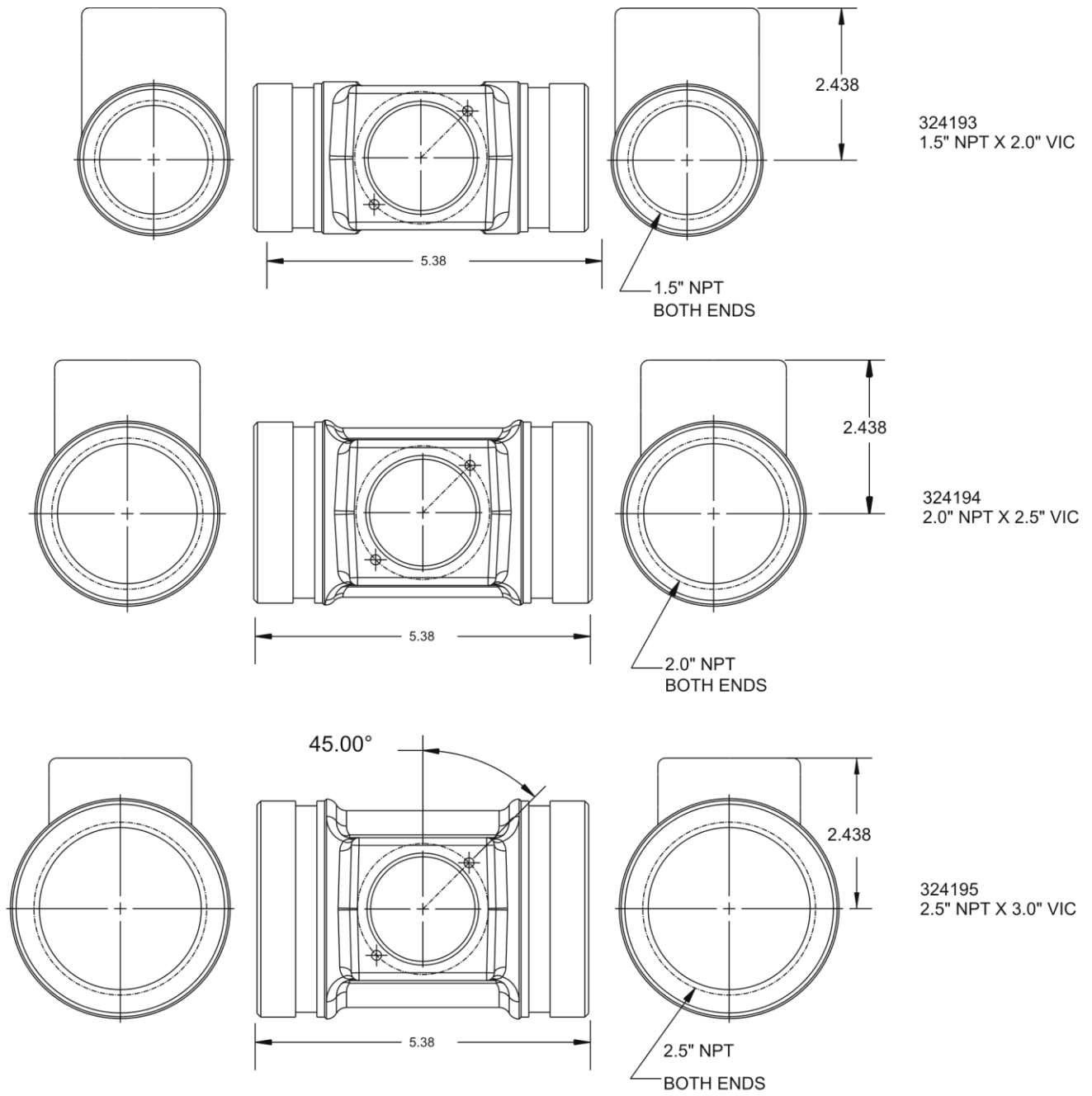

Figure 9 Aquis Z Bracket Mount Bolt Pattern



FLOW TEE - CAST BRASS

NOTES:
DIMENSIONS ARE APPROXIMATE
DESIGN AND SPECIFICATIONS SUBJECT TO CHANGE WITHOUT NOTICE

Figure 10 Aquis Flow Tees

SECTION 9. PARTS LIST

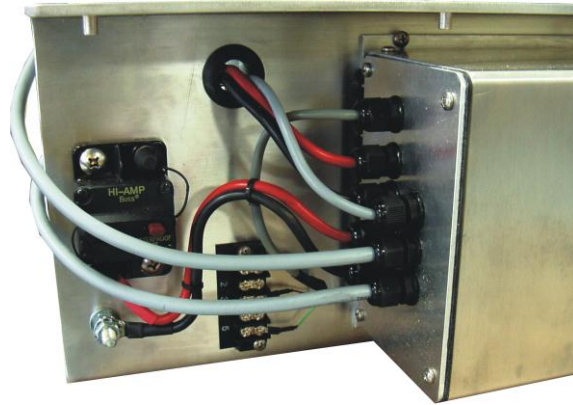
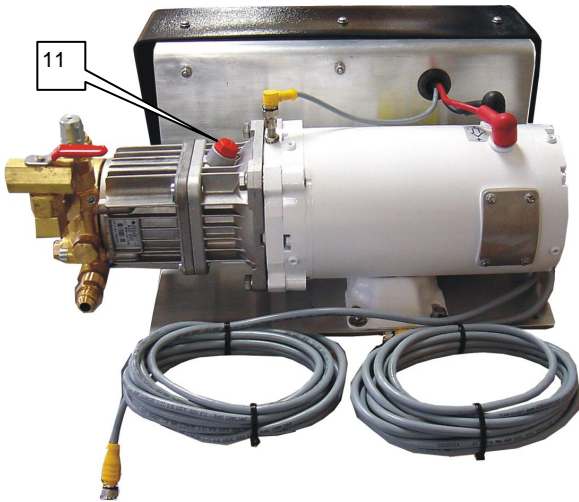

↑ Item 04 ↑



06↑

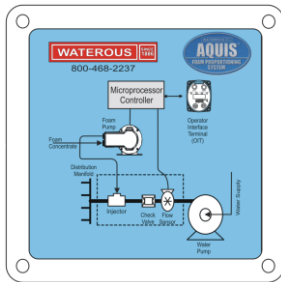
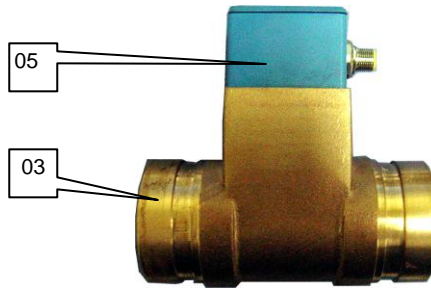

01↑

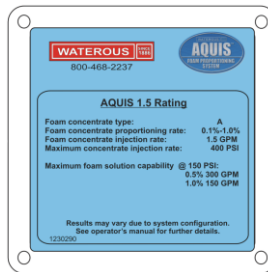

02↑

Item	Part #	Description	Details	Qty
01	0315315	Schematic Plate		1
02	0315321	Performance Plate		1
03	0324175	Flow Tee SS 1.5 NPT-2.0 VIC		1
04	0390186 0390187 4190017	1.5 T Motor/Pump/ Control Kit Paddle Wheel Flow-meter/Temp	12VDC 24VDC	1

Item	Part #	Description	Details	Qty
06	4290039	1.5 OIT Assembly		1
07	4310006	Cable Extension – OIT	3m	1
08	4310007	Cable Extension – OIT	6m	1
09	4310002	Cable Extension –Flow-meter	2m	1
10	4310003	Cable Extension –Flow-meter	3m	1
11	5030057	Vented Fill cap		1

SECTION 10. CONDITIONAL 1-YEAR WARRANTY POLICY

WATEROUS warrants, to the original Buyer only, that products and parts manufactured by WATEROUS will be free from defects in material and workmanship under normal use and service for a period of one (1) year from the date the product is first placed in service, or one and one-half (1-1/2) years from the date of shipment by WATEROUS, whichever period shall be the first to expire; provided the Buyer notifies WATEROUS, in writing, of the defect in said product within the warranty period, and said product is found by WATEROUS to be nonconforming with the aforesaid warranty. When required in writing by WATEROUS, defective products must be promptly returned by Buyer to WATEROUS at WATEROUS plant at Glendale, Arizona, or at such other place as may be specified by WATEROUS, with transportation and other charges prepaid. A Returned Material Authorization (RMA) is required for all products and parts and may be requested by phone, fax or mail. The aforesaid warranty excludes any responsibility or liability of WATEROUS for:

- a) damages or defects due to accident, abuse, misuse, abnormal operating conditions, negligence, accidental causes, or improper maintenance, or attributable to written specifications or instructions furnished by Buyer;
- b) defects in products manufactured by others and furnished by WATEROUS hereunder, it being understood and agreed by the parties that the only warranty provided for such products shall be the warranty provided by the manufacturer thereof which, if assignable, WATEROUS will assign to Buyer, if requested by Buyer;
- c) any product or part, altered, modified, serviced or repaired other than by WATEROUS, without its prior written consent; and
- d) the cost of dismantling, removing, transporting, storing, or insuring the defective product or part and the cost of reinstallation.
- e) normal wear items (including, but not limited to belts, hoses, check valves, packing, strainers, filters, light bulbs, anodes, intake screens, mechanical seals, etc.).

This warranty is subject to WATEROUS Conditions of Sale (detailed on WATEROUS Invoice) as currently in effect all of which are herein incorporated and by this reference made a part hereof

All other warranties are excluded, whether express or implied by operation of law or otherwise, including all implied warranties of merchantability or fitness for purpose. WATEROUS shall not be liable for consequential or incidental damages directly or indirectly arising or resulting from the breach of any of the terms of this limited warranty or from the sale, handling, or used of any WATEROUS product or part. WATEROUS liability hereunder, either for breach of warranty or for negligence, is expressly limited at WATEROUS option:

- a) to the replacement at the agreed point of delivery of any product or part, which upon inspection by WATEROUS or its duly authorized representative, is found not to conform to the limited warranty set forth above, or
- b) to the repair of such product or part, or
- c) to the refund or crediting to buyer of the net sales price of the defective product or part. Buyers remedies contained herein are exclusive of any other remedy otherwise available to Buyer.

Waterous, Arizona Operations
7612 North 74th Ave.
Glendale, Arizona 85303
www.waterousco.com



Compressed Air Foam Systems